

Authorised Specialists and Operators

# manual

## Installation and Operating Instructions

Series HSC-Electric / 300210-DE/UK-A

English



**HSC840-INOX 24 kW**  
**HSC1140-INOX 30 kW**



**HSC840-INOX FR 24 kW**  
**HSC1140-INOX FR 30 kW**

# Declaration of Conformity

**Manufacturer:**

**Ehrle GmbH**

**Address:**

**Industriestraße 3  
D – 89165 Dietenheim**

**Product:**

Stationary Hotwater High Pressure Cleaners

**Series HSC-Electric (DE/UK)**

**Series HSC-Electric FR (DE/UK)**

**This product given below is in conformity with the European Directives:**

**Relevant EC Directives:**

2000/14/EC  
2006/42/EC  
2011/65/EU  
2014/30/EU  
2004/108/EC  
2014/35/EU

**Applied harmonized standards:**

EN 60335-1: 2024-07  
EN 60335-2-79: 2021-07  
EN 50581: 2019-05  
EN 55014-1: 2006+A1: 2009+A2: 2011  
EN 55014-2: 2022-10  
EN 62233: 2008-11  
EN IEC 61000-3-2: 2023-10  
EN 61000-3-3: 2023-02

**Conformity procedures applied:**

2000/14/EC: Annex V

This product conforms to  
the following directives:

**UK UK  
CA NI**

**CE**

Dietenheim, 06.10.2025

Development

ppa.



Christoph Nöldner

Head of Development



Reiner Ehrle

CEO

Table of content

1	User information	
1.1	General .....	5
1.2	System concept .....	5
1.3	Terminology.....	6
1.4	Meaning of the emphasis.....	6
1.5	Meaning of the symbols.....	7
1.6	Target group.....	8
1.7	Warranty and Liability.....	9
1.8	Environmental protection.....	10
2	Sicherheit	
2.1	General safty information.....	11
2.2	Duty of care for the plant operator .....	11
2.3	Access for persons to the system .....	12
2.4	Safety instructions for cleaning operation for system operators and operating personnel .....	12
2.5	Accident prevention regulations.....	14
2.6	Lifting and moving loads.....	14
2.7	Periodic inspections.....	14
2.8	System operator obligations.....	14
2.9	Manufacturer tests and certificates .....	14
2.10	Guidelines for liquid sprayers .....	14
2.11	Safety regulations electrical connection.....	15
2.12	Design changes to the system.....	15
2.13	Safety devices.....	15
3	Product description	
3.1	System views.....	16
3.1.1	Series HSC-Electric INOX .....	16
3.1.2	Series HSC-Electric INOX, interior with additional kit 265300 .....	18
3.1.3	Series HSC-Electric INOX FR .....	19
3.1.4	Series HSC-Electric INOX, interior with additional kit 265300 .....	21
3.2	Type plates .....	22
3.2.1	Series HSC-Electric INOX .....	22
3.2.2	Series HSC-Electric INOX FR .....	22
3.3	Serial number .....	22
3.4	Technical data.....	23
3.4.1	HSC840-INOX 24kW / HSC1140-INOX 30kW .....	23
3.4.2	HSC840-INOX FR 24kW / HSC1140-INOX FR 30kW.....	25
3.5	Selection of spray nozzles.....	26
4	Installation	
4.1	Selection of the operating location.....	27
4.2	Installation material .....	30
4.3	Installation of the electrical connection .....	32
4.4	Establishing the water connection .....	33

4.5	Assembly of washing station equipment.....	34
4.6	Setting up the detergent container .....	34
5	Commissioning	
5.1	Measures prior to commissioning.....	39
5.2	First switch-on after installation .....	39
6	Operation	
6.1	System indicator and control elements.....	42
6.1.1	Control elements on the cabinet front door .....	42
6.1.2	Control elements of the trigger gun .....	43
6.1.3	Control and indicator elements in the cabinet.....	44
6.2	Measures for system operators before operation .....	46
6.3	Notes on operation for specialist and operating personnel .....	46
6.4	EMERGENCY STOP - switch-off in case of danger .....	48
6.5	System setting and operation for skilled personnel.....	48
6.6	System operation for operating personnel .....	51
6.7	Use of detergents (chemistry).....	53
6.7.1	Adjust the amount of detergent to be added .....	55
6.7.2	Adding detergent .....	55
7	Decommissioning	
7.1	Temporary decommissioning by operating personnel .....	56
7.2	Temporary decommissioning by qualified personnel .....	57
7.3	Decommissioning for a longer period of time.....	58
8	Maintenance	
8.1	General Information .....	59
8.2	EHRLE Maintenance and Inspection Contract .....	59
8.3	Maintenance work.....	59
8.3.1	Frost protection .....	61
8.3.2	Cleaning the filter in water inlet .....	61
8.3.2.1	HSC-Electric.....	61
8.3.2.2	HSC-Electric FR.....	62
8.3.3	Oil change.....	62
8.3.4	Checking the HP-Hoses .....	62
9	Troubleshooting	
9.1	Troubleshooting table.....	63
9.2	Replacement of components and parts .....	66
10	Circuit diagrams	
10.1	HSC840-INOX 24kW.....	68
10.2	HSC1140-INOX 30 kW .....	72
10.3	HSC840-INOX FR 24 kW .....	76
10.4	HSC1140-INOX FR 30 kW .....	88
11	General Notes	

# 1 User information

## 1.1 General



### General information

For a comprehensive advice and information on the Stationary Hotwater High Pressure Cleaners of the Series HSC-Electric please contact the EHRLE Customer Service.

With the purchase of an EHRLE Stationary Hotwater High Pressure Cleaner of the Series HSC-Electric you are the owner of a quality product, which is characterised by:

- user-friendliness,
- reliability,
- environmental friendliness.

These Installation and Operating Instructions are part of the Stationary Hotwater High Pressure Cleaners of the Series HSC-Electric and must be kept at the operating site and available at all times.

For the Stationary Hotwater High Pressure Cleaners of the Series Electric, the manual contains information on

- User information
- Safety
- Product information
- Installation
- Commissioning
- Operation
- Decommissioning
- Maintenance
- Troubleshooting
- Circuit diagrams.

## 1.2 System concept

The Stationary Hot Water High Pressure Cleaners are designed for two separate operating levels with different access rights

- **Level 1 for system operators** with access to
  - control and indicator elements inside the cabinet via the lockable door
  - three main switches resp. push buttons (version FR) on the front of the cabinet door.

The control elements in the cabinet are used to set operating parameters such as

- operating pressure
- water temperature
- detergent quantity.

- **Level 2 for operating personnel** with exclusive access to the three main switches resp. push buttons (Version FR) on the front of the cabinet door. On the front of the cabinet door, the three main switches resp. push buttons (Version FR) can be switched on/off:
  - system operation
  - hot water mode
  - admixture of detergent.

### 1.3 Terminology

In this manual the terminology listed below is replaced by the relevant short terms whenever possible:

- Stationary Hotwater High Pressure Pressure Cleaner High pressure cleaner
- Installation and Operating Instructions Manual
- Frost protection FR (e.g. HSC840-INOX FR 24kW)
- High pressure nozzle HP-nozzle
- High pressure hose HP-hose

If a clear reference to a subject is required in the description parts, the terminology „Stationary Hotwater High Pressure Cleaners of the Series HSC-Electric“ is used.

### 1.4 Meaning of the emphasis

The emphasis used in this manual have the following meanings:

#### WARNING

Warning precedes operating procedures, instructions, etc., which, if not strictly observed, could result in personal injury or loss of life. Warning precedes also, when device misuse could result in personal injury or loss of life.





#### CAUTION







Caution precedes operating procedures, instructions, etc., which, if not strictly observed, could result in damage to the high pressure cleaner. Caution precedes also, when device misuse could result in damage to the high pressure cleaner.



This symbol indicates additional information.

## 1.5 Meaning of the symbols

Symbol	Meaning
	<p><b>WARNING</b>  <b>Follow instructions.</b>                      Non-observance or neglecting of prescribed instructions, incorrect operation or misuse of the system may endanger life and limb of persons.</p>
	<p><b>WARNING</b>  <b>Danger of death due to electric shock.</b>                      Switch off the system and disconnect it from the power supply before starting installation, maintenance and repair work.                      Protect the system from unconscious switching on.                      Touching live parts can lead to life-threatening injuries.</p>
	<p><b>WARNING</b>  <b>Explosion hazard due to use of unauthorised cleaning agents.</b>                      Never add liquids containing solvents such as paint thinners, petrol or similar to the high pressure jet.                      The spray mist of solvents is highly flammable, explosive and toxic                      Otherwise, life and limb of persons is in danger.</p>
	<p><b>WARNING</b>  <b>Risk of burns and scalding</b>                      When operating with a water temperature of up to 80 °C, the cleaning objects, the escaping hot water, surfaces of system parts, assemblies or components can become hot.                      Touching hot surfaces or hot water can lead to burns or scalds on the surface of the skin.                      Make sure that the surfaces and the water have cooled down before touching them                      The hot water emerging from the trigger gun must not come into contact with the skin                      Touching hot surfaces or coming into contact with hot water can lead to burns or scalding of the skin surface</p>

Symbol	Meaning
	<p><b>WARNING</b>  <b>Danger with heavy loads.</b>                      A person is not allowed to lift and move loads more than 23 kg.                      Otherwise the health of persons may be endangered (e.g. overload of the spinal column, injuries from falling loads).                      For loads of more than 23 kg, use suitable lifting equipment (e.g. forklift truck, lift truck).</p>
	<p><b>CAUTION</b>  <b>Observe instructions for installation, device adjustment, operation, maintenance and repair.</b>                      Non-observance or neglecting prescribed instructions, incorrect operation or misuse of the system may result in damage to system parts, assemblies or components.</p>
	<p><b>General Information</b>                      General additional information.</p>
	<p><b>Information on recycling.</b>                      General information on recycling.</p>
	<p><b>Information on disposal.</b>                      General information on the proper and environmentally friendly disposal of materials and consumables.</p>
	<p><b>Information on hearing protection.</b>                      General information on hearing protection.</p>
	<p>Requires direct action.</p>

## 1.6 Target group

These manual contain information and instructions for:

- Authorised, instructed and trained operating personnel to carry out cleaning work.
- Authorised, qualified and trained personnel to carry out installation, operation, maintenance, repair and adjustment of the system.

## **1.7 Warranty and Liability**

The Stationary Hotwater High Pressure Cleaners of Series HSC-Electric may only be used for its intended purpose.

Intended use includes:

- Operation only by personnel who
  - are instructed and trained on the system, or
  - have read and understood the information and instructions in these Installation and Operating Instructions in full and can thus ensure safe handling of the system.
- The information and instructions contained in this Installation and Operating Instructions must be observed.
- Installation, operation, maintenance, repair and adjustment of the system only by qualified, trained and authorized personnel. For installation, maintenance, repair and adjustment of the system, the relevant specialist personnel can be consulted and commissioned by the EHRLE Customer Service.
- If the safety and protective devices are faulty, the system must not be put into operation.
- The system may only be operated with fully functional safety and protective devices. In the event of functional failures during operation, the system must be taken out of operation immediately
- Faulty, insufficient or defective systems must not be put into operation. Before commissioning, carry out a visual inspection for faulty, defective or defective
  - system parts, assemblies or components
  - electrical cables
  - HP-Hoses.
- The system must be switched off immediately and taken out of operation if defects, faults or deficiencies occur on
  - system parts, assemblies or components
  - electrical cables
  - HP-Hoses.
- No constructive changes may be made to the system.
- The system may only be operated in the configuration certified by the manufacturer. Operation with subsequently installed modules, components or additional devices is not permitted and may endanger life and limb of persons or lead to damage to the system.
- Only original parts from the manufacturer or consumables approved by the manufacturer may be used for maintenance and repair work
- Only fuels and operating materials approved by the manufacturer may be used for the operation of the system.
- Only consumables approved by the manufacturer (engine oil, cleaning agents, etc.) may be used for the operation of the system.

Any warranty and liability claims for personal injury and damage to the system are void if the system is not used for its intended purpose.

## 1.8 Environmental protection



### Note on recycling.

The packaging materials are recyclable. Please do not throw the packaging into the household waste, but recycle it.



### Note on disposal.

Old appliances, assemblies or system parts contain valuable recyclable materials that should be sent for possible recovery.

The old appliances must not be disposed of together with unsorted municipal waste (household waste). The symbol with the crossed-out dustbin on the appliance indicates this obligation.

Therefore, please dispose of discarded devices, assemblies or parts properly via suitable collection systems.

Dispose of used materials in an appropriate and environmentally friendly manner. Observe the local regulations.

Old appliances, assemblies or system parts contain valuable recyclable materials that should be recycled.

According to environmental regulations, lubricants such as oils and greases must not get into the ground, water or sewer system.

Do not allow lubricants such as oils and greases to be released into the environment. Protect the soil and dispose of lubricants in an environmentally friendly manner.

## 2 Safety

### 2.1 General safety information

Observe the respective national regulations of the legislator for liquid sprayers. Liquid sprayers must be inspected regularly and the result of the inspection must be recorded in writing.

Observe the relevant national regulations of the legislator on accident prevention.

Observe the safety data sheets and instructions of the cleaning agent manufacturers supplied with the detergents used (usually on the packaging label).

Keep cleaning agents out of the reach of unauthorized persons. Risk of poisoning or caustic burns from cleaning agents! Observe the instructions on the cleaning agents.

Perform prescribed adjustment, maintenance and inspection work in due time (see Section 8, Maintenance).

Safety-relevant defects must be rectified immediately. Observe all warning and information signs attached to the unit. Keep all signs on the device legible.

### 2.2 Duty of care for the plant operator

It is the duty of care of the plant operator to ensure that all safety regulations, instructions and information for comprehensive operation are observed and monitored by the maintenance personnel. The information and instructions contained in this Installation and Operating Instructions must be observed.

The plant operator must ensure:

- The system may only be operated in a technically perfect condition and in accordance with its intended purpose, with an awareness of safety and dangers, and in compliance with this manual.
- Before each commissioning of the liquid sprayer, its safety-relevant parts must be checked for their perfect condition (safety relief valves, HP-Hoses, trigger gun, trigger gun electrical cables etc.).
- Take the system out of operation immediately or do not put it into operation under any circumstances if damage or destruction is found on the system, the fastening parts or the power supply or if safe operation cannot be guaranteed.
- If parts are damaged, incorrect operation or other defects, stop operation immediately or do not use the system. Immediately rectify any damage, incorrect operation or function and contact customer service if necessary.
- In order to carry out the maintenance tasks comprehensively, the maintenance personnel must be regularly trained and instructed in relation to occupational safety and environmental protection.
- The areas of responsibility, competences and monitoring of the maintenance personnel must be regulated by the plant operator.
- The currently applicable local accident prevention regulations, the local industrial safety regulations and other safety-related rules and regulations as well as the operating instructions must be observed.
- In addition to this manual, the generally applicable and local regulations for accident prevention and environmental protection must be made available and observed.

## **2.3 Access for persons to the system**

The cabinet door for access to the interior of the cabinet must be kept locked. Only authorised persons may have access to the inside of the cabinet.

Ensure that access to the system is only possible for the following persons:

- Operating personnel authorised, instructed and trained by the system operator and specially trained for general cleaning tasks. Operation is limited to the three main switches on the front of the cabinet door.
- Authorised, qualified and specially trained personnel for the installation, operation, maintenance, repair and adjustment of the system. Access to the key for the cabinet door in order to be able to carry out appropriate measures inside the cabinet.

Keep the key for the cabinet access door in a place accessible only to authorised personnel.

## **2.4 Safety instructions for cleaning operation for system operators and operating personnel**

During cleaning work, the personnel at the workplace must wear the necessary Personal Protective Equipment (PPE). This includes waterproof protective suits, rubber boots, protective goggles, headgear, ear protection if necessary, etc.

No cleaning work may be carried out in the presence of persons without sufficient protective clothing.

Before switching on, carry out a visual inspection of the system parts from the outside for damage (HP-Hose, electrical or mechanical parts). Systems with damaged parts, assemblies or components must not be put into operation.

The water jet leaving the trigger gun must not be directed at:

- persons
- animals
- live electrical installations (building mains connections, sockets, electrical wiring, etc.)
- live electrical installations, machines, devices, assemblies or components
- system, machinery or equipment in operation.

Under the influence of the high pressure jet, parts can be separated from the cleaning object and thrown away. Persons can be injured as a result.

Never aim the high pressure jet at fragile or loose objects.

When cleaning tyres and their valves, keep a minimum distance of 30 cm from the high pressure nozzle. Otherwise damage may occur.

Before cleaning the high pressure cleaner itself, take the system out of operation and disconnect it from the electrical mains connection. Secure the system against unintentional or unauthorised restarting (e.g. lock main switch, disconnect mains cable from power outlet, provide warning sign indicating work on the high pressure cleaner, etc.).

Never operate the system unattended.

The system is designed for a water temperature of up to 80 °C temperatures. When operated with hot water, water-carrying parts (for example pump housing, uninsulated pipes, metal parts of the trigger gun and spray lance) as well as cleaning objects may become hot. Touching hot surfaces can cause burns of the skin surface. Make sure surfaces have cooled before touching.

The hot water escaping from the trigger gun must not come into contact with the skin. Contact with hot water can cause scalding. After hot water operation, wait until the water has cooled down again.

Asbestos-containing and other materials containing substances hazardous to health must not be sprayed off.



### **Information on hearing protection**

If the sound levels exceed the permissible values, the personnel and persons in the area of exposure must wear hearing protection.

The sound level for EHRLE high pressure cleaners under maximum load is 82 dB (A). A high sound level over a long period can cause hearing loss. If the noise produced by the application of the emerging high pressure jet to noise-enhancing objects exceeds the permissible values, the operating personnel and any persons affected must wear hearing protection.

Do not operate the system if electrical cables or other safety-relevant parts (unloader valve, HP-Hose, trigger gun, etc.) are defective.

Before changing the cleaning agent, flush out the complete high pressure system for minimum 2 minutes by pulled trigger gun. This avoids subsequent dangerous chemical reactions.

Aerosols can be formed when using high pressure cleaners. An aerosol is a mixture of solid or liquid suspended particles in a gas. Inhaling aerosols can be harmful for your health.

Employers are obliged to perform a hazard assessment in order to define, depending on the surface to be cleaned and the environment, protective measures necessary to prevent inhalation of aerosols.

Respiratory protection masks of class FFP 2 or above are suitable for protection against aqueous aerosols.

Using the device for longer periods can cause poor circulation in the hands due to vibrations. A general period of use cannot be set, because this depends on several influencing factors:

- Personal tendency to suffer from poor circulation (frequently cold fingers, tingling sensation in the fingers).
- Low ambient temperature. Wear warm gloves to protect your hands.
- Holding the device too tightly hindering blood circulation.
- Continuous operation is more harmful than operation interrupted by work breaks.

You should see a doctor if using the device regularly and for lengthy periods of time, and in the event of repeated occurrences of symptoms such as tingling in the fingers or cold fingers.

The high pressure cleaners must not be set up and operated in rooms where there is a risk of fire or explosion.

Using high pressure cleaners in gas-stations or other hazardous area:

- refer to „Technical Rules for Flammable Liquids“ (TRGF)
- the relevant safety regulations must be observed.

Observe the local regulations regarding the installation and operation of the high-pressure cleaner.

The HP-hose do not

- run over, pull excessively or twist
- pull over sharp edges
- repair.

Replace the defective HP-hose with an HP-hose approved by the manufacturer.

## **2.5 Accident prevention regulations**

Observe the applicable national regulations of the legislator on accident prevention.

## **2.6 Lifting and moving loads**

The Stationary Hotwater High Pressure Cleaners of the Series HSC-Electric weigh 264 kg and 292 kg (with packaging 281 kg and 309). Components of the highpressure cleaners can have a weight of more than 23 kg.

Lifting and moving loads is permitted for one person up to 23 kg. If the load exceeds 23 kg use suitable lifting equipment (e.g. forklift, lift trucks).

Observe the international standard „ISO 11228-1 Ergonomie - Manuelles Handhaben von Lasten - Teil 1 Heben und Tragen 05/2003“.

## **2.7 Periodic inspections**

The periodic inspections are listed in Section 8 (Maintenance).

## **2.8 System operator obligations**

The plant operator must ensure that the safety-relevant parts of the liquid sprayer are checked for perfect condition before each start-up (safety valves, HP-Hose, trigger gun, electric cables etc.).

## **2.9 Manufacturer tests and certificates**

Acceptance test of the high pressure cleaner (test report is part of the scope of delivery).

## **2.10 Guidelines for liquid sprayers**

High pressure cleaners must be inspected by an expert in accordance with the „Guidelines for liquid sprayers“, if necessary or at least every 12 months. The result of the test must be recorded in writing.

In the appendix of this manual there is a test sheet (proof of customer service) to record the tests carried out.

EHRLE service technicians are experts and can be consulted and commissioned by EHRLE service for this prescribed inspection.

## **2.11 Safety regulations electrical connection**

When working on electrically live parts:

- Observe accident prevention regulations DGUV V3 (previously BGV A3) and local regulations,
- use tools according to DIN EN 60900.

## **2.12 Design changes to the system**

Design changes to the high pressure cleaner are not permitted.

When operating a system which has been modified or changed in design, the system will not be used for its intended purpose. If the system is not used for its intended purpose, no liability or warranty will be accepted (see Section 1.7, Warranty and Liability).

## **2.13 Safety devices**

Safety devices serve to protect the user and must not be suspended or circumvented in their function.

The high pressure cleaner has the following safety devices:

- Various pressure switches:  
System functions are switched on or off (safety functions) based on type of construction and intended use.
- Low-water cut-off:  
The system does not switch on, respectively in case of operation off, if the water level in the electrically heated boiler is insufficient.
- Unloader valve and non-return valve:  
The first serves to adjust the operating pressure and the second valve keeps the pump head depressurised when the trigger gun is deactivated.
- Thermostat and overload protection switch:  
Releases when the pump current load is too high, the system is switched off.
- TSS system with pump-off delay:  
After deactivating the trigger gun, the pump continues operation for approx. 30 s in the pressureless bypass mode (avoidance of too high pressure buildup in the pump); then the motor is switched off.
- Total Switch-off:  
Automatically switches the high pressure cleaner off in the event of prolonged interruption of operation or unused trigger gun for more than 20 minutes.
- Leakage detection:  
Switches the high-pressure cleaner off automatically after a leakage is detected
  - on the HP-hose
  - with the trigger gun or
  - in the system.
- Mechanical arrest for trigger gun:  
Prevents unintentional or unconscious activating the trigger gun.

### 3 Product description

#### 3.1 System views

##### 3.1.1 Series HSC-Electric INOX

The following figures show a general example for the Stationary Hotwater High Pressure Cleaners of Series HSC-Electric INOX.

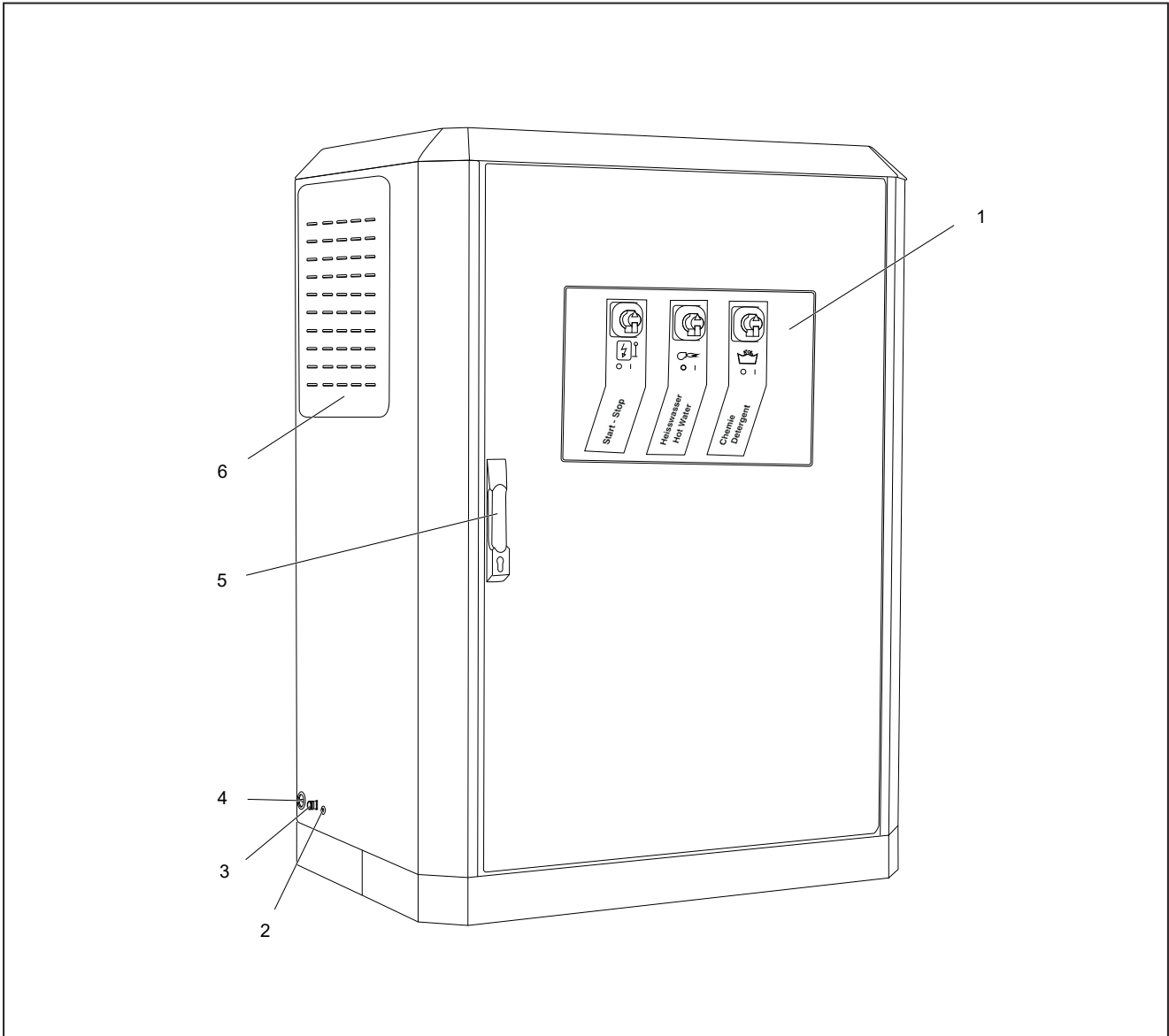

- |   |                                   |   |                                    |
|---|-----------------------------------|---|------------------------------------|
| 1 | Control panel, cabinet door front | 4 | Feed-through electrical connection |
| 2 | HP-Hose feed-through              | 5 | Door latch with lock               |
| 3 | Feed-through water connection     | 6 | Cover maintenance opening          |

Fig. 3 - 1 Stationary Hotwater High Pressure Cleaners Series HSC-Electric, total view

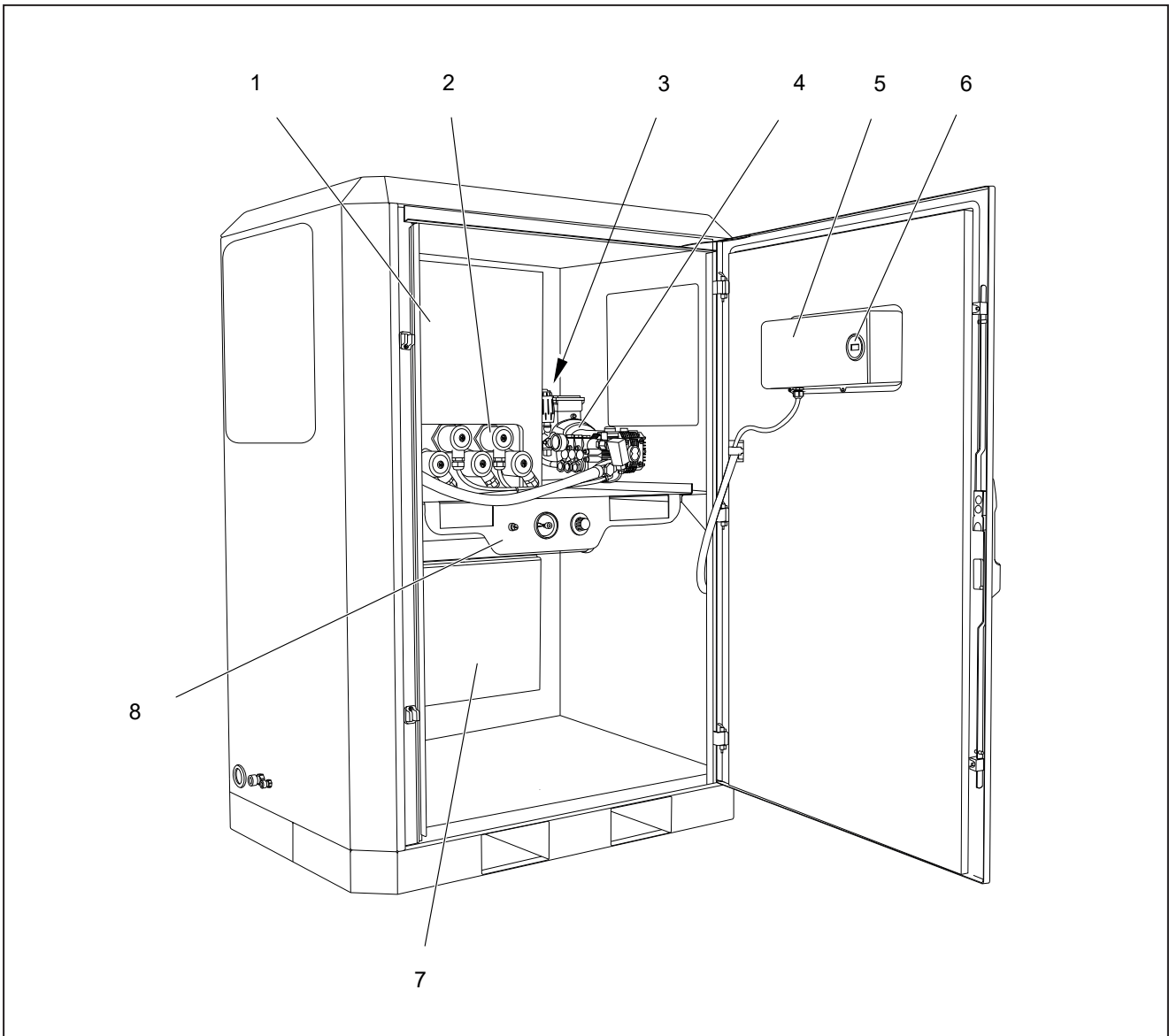

- |   |   |   |   |
|---|---|---|---|
| 1 | Electrically heated boiler  | 5 | Protective cover (terminal contacts main switches)  |
| 2 | Heating element   | 6 | Service hour meter  |
| 3 | Chemical pump   | 7 | Electrical control box  |
| 4 | Pump unit with drive motor, unloader<br>safety valve for variable pressure and<br>quantity regulation as well as pressure gauge | 8 | Control panel with maximum thermostat<br>max. 95 °C, thermostat max. 80 °C and detergent<br>control valve |

Fig. 3 - 2 Stationary Hotwater High Pressure Cleaners Series HSC-Electric, view to cabinet interior (door opened)

### 3.1.2 Series HSC-Electric INOX, interior with additional kit 265300



#### General Information

In this system version, the lance quiver does not have a frost protection function.

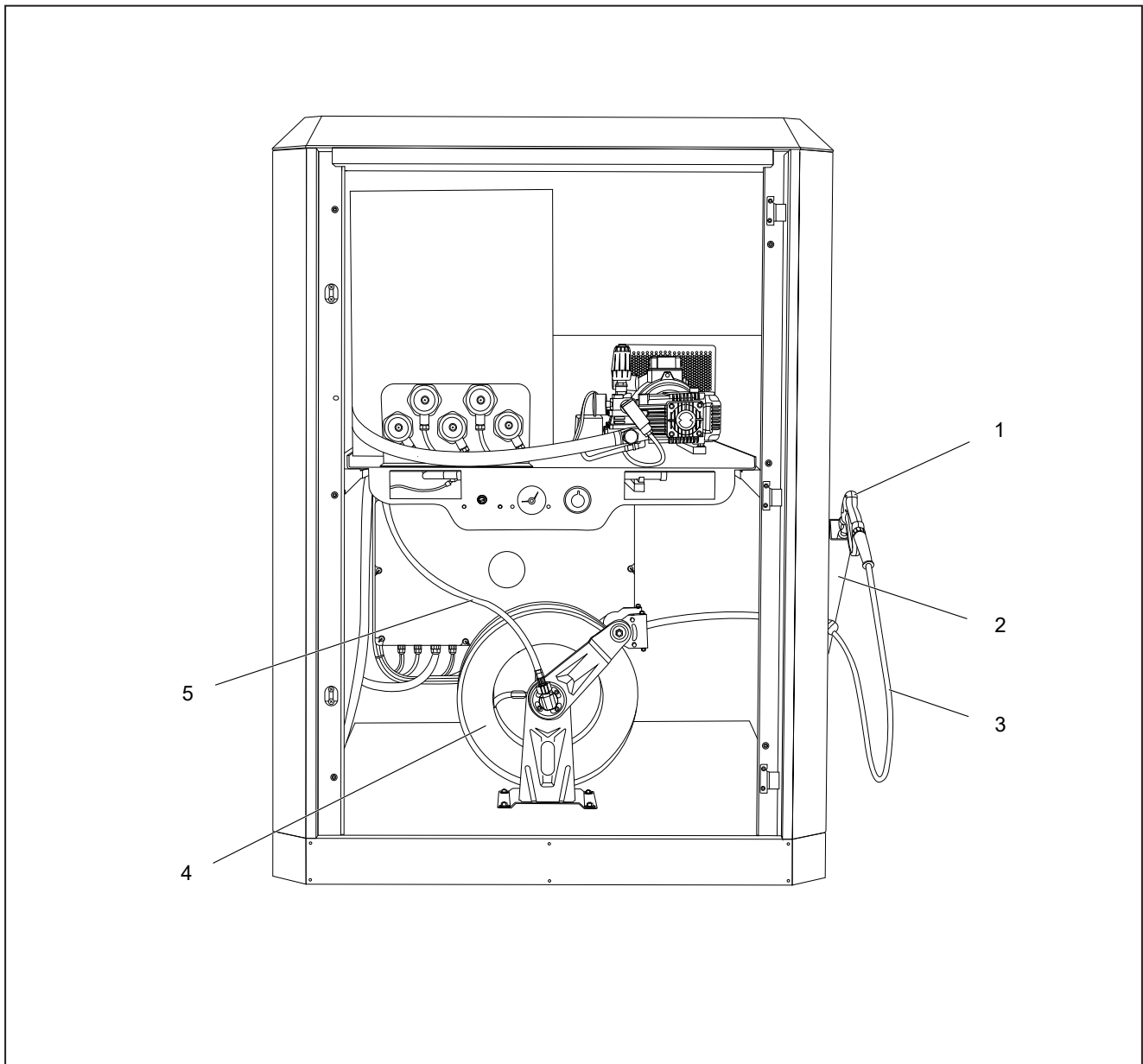

- |   |   |   |                     |
|---|---|---|---------------------|
| 1 | Spray lance with trigger gun, nozzle protection and HP-nozzle | 3 | HP-hose 20 m        |
| 2 | Lance quiver with water drain integrated                      | 4 | Automatic hose reel |
| 5 | Connection hose   |   |                     |

Fig. 3 - 3 Stationary Hotwater High Pressure Cleaners Series HSC-Electric, cabinet interior equipped with mit additional kit 265300

### 3.1.3 Series HSC-Electric INOX FR

The following figures show a general example for the Stationary Hotwater High Pressure Cleaners of Series HSC-Electric FR.

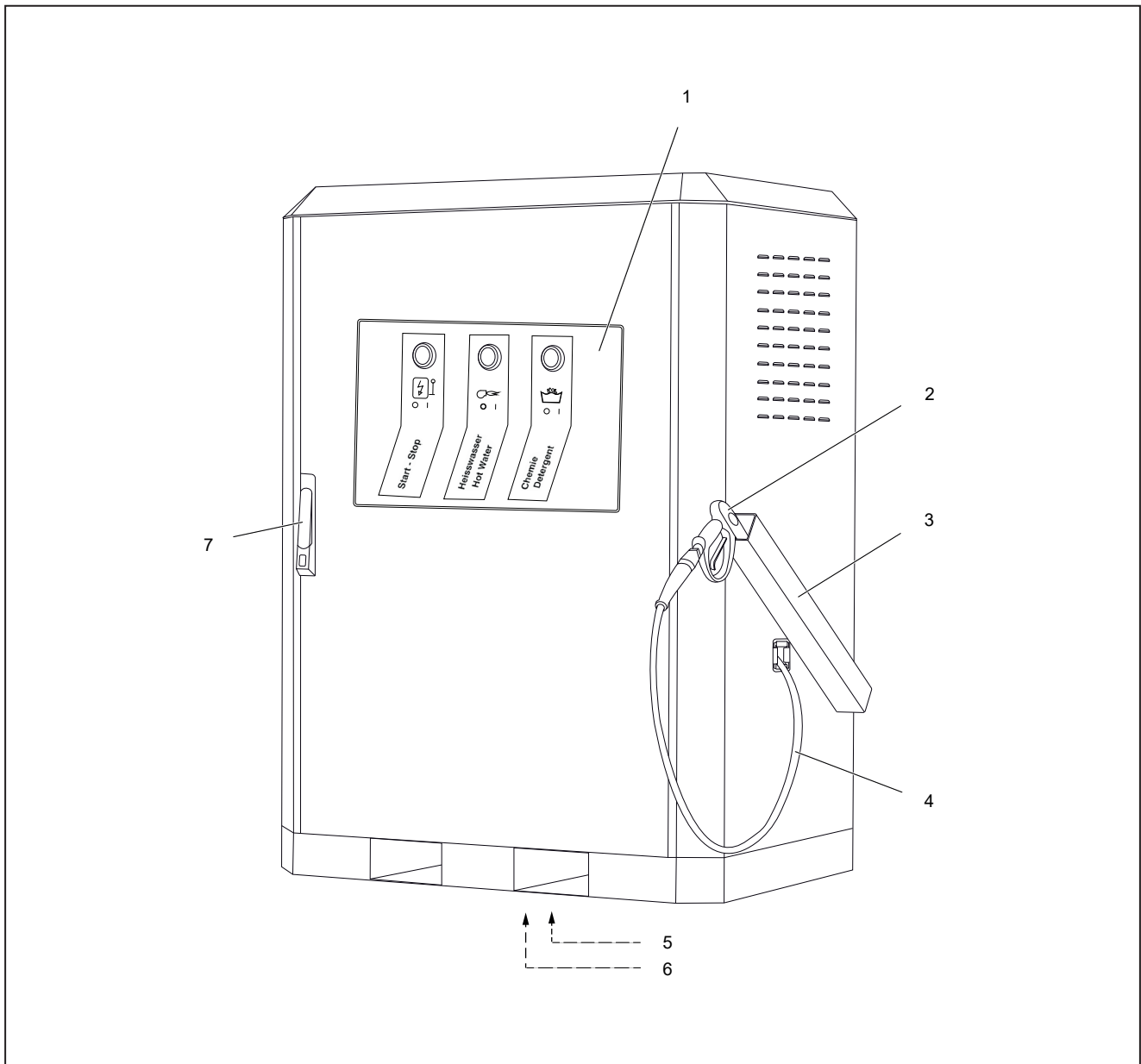

- |   |                                   |   |   |
|---|-----------------------------------|---|---|
| 1 | Control panel, cabinet door front | 5 | Feed-through water connection via the base of the system cabinet      |
| 2 | Trigger gun                       | 6 | Feed-through electrical connection via the base of the system cabinet |
| 3 | Lance quiver                      | 7 | Door latch with lock  |
| 4 | HP-hose 10 m                      |   |   |

Fig. 3 - 4 Stationary Hotwater High Pressure Cleaners Series HSC-Electric FR, total view

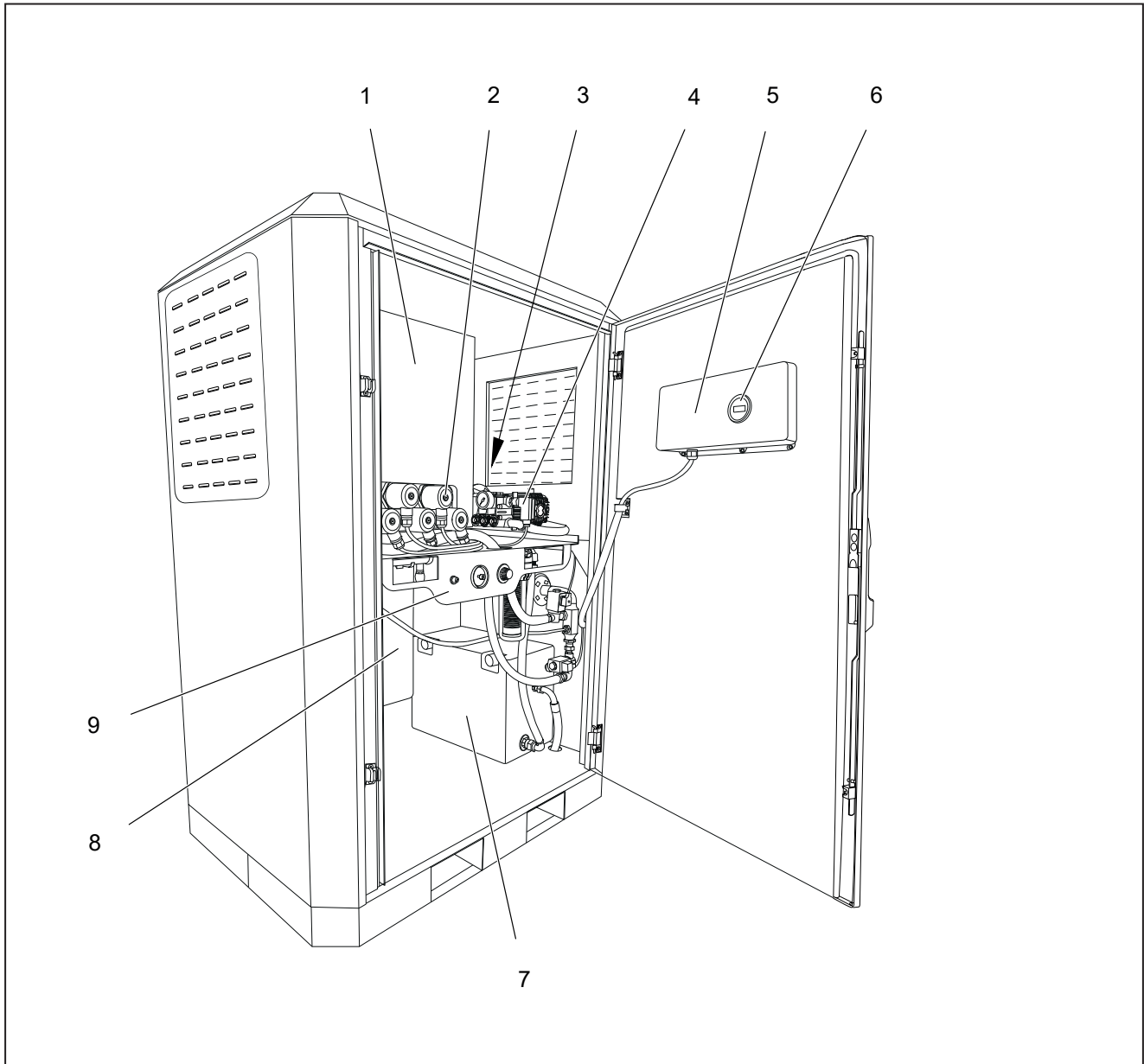

- |   |   |   |   |
|---|---|---|---|
| 1 | Electrically heated boiler  | 6 | Service hour meter  |
| 2 | Heating element   | 7 | Anti freeze tank (WAB) with anti freeze circulatory system  |
| 3 | Chemical pump   | 8 | Electrical control box  |
| 4 | Pump unit with drive motor, unloader safety valve for variable pressure and quantity regulation as well as pressure gauge | 9 | Control panel with maximum thermostat max. 95 °C, thermostat max. 80 °C and detergent control valve |
| 5 | Protective cover (terminal contacts main switches)  |   |   |

Fig. 3 - 5 Stationary Hotwater High Pressure Cleaners Series HSC-Electric FR, view to cabinet interior (door opened)

### 3.1.4 Series HSC-Electric INOX, interior with additional kit 265300

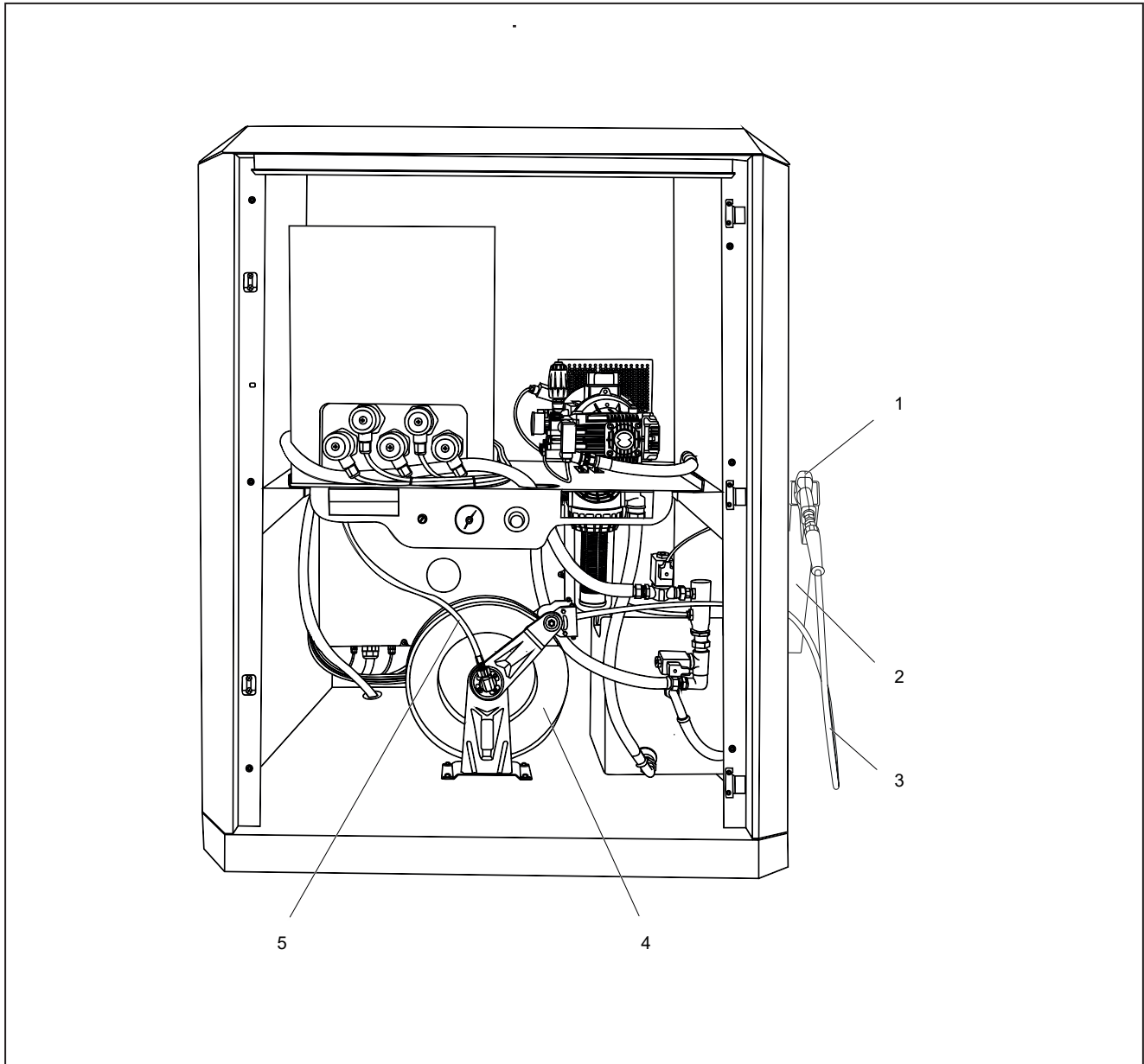

- |   |   |   |  |
|---|---|---|--|
| 1 | Trigger gun with low-pressure leakage, spray lance, nozzle protection and HP-nozzle | 3 | HP-hose 10 m (Series)  |
| 2 | Lance quiver with water drain into the anti freeze tank (WAB)                       | 4 | Optional to position 3 automatic hose reel with connection hose and 20 m HP-hose |
|   |   | 5 | Connection hose  |

Fig. 3 - 6 Stationary Hotwater High Pressure Cleaners Series HSC-Electric FR, view to the HP-hose components inside the cabinet

### 3.2 Type plates

#### 3.2.1 Series HSC-Electric INOX

<p><b>HSC840-INOX 24kW</b></p> <p>Type: HSC840-INOX 24kW 531-XX-B </p> <table border="1" style="width: 100%; border-collapse: collapse;"> <tr><td>Voltage</td><td>3/N/PE/AC/400-415V/50Hz</td></tr> <tr><td>Operating pressure</td><td>30-130bar/3-13MPa</td></tr> <tr><td>Max. pressure</td><td>150bar/15MPa</td></tr> <tr><td>Discharge capacity</td><td>300 - 720l/h</td></tr> <tr><td>Nozzle size</td><td>045</td></tr> <tr><td>Heating power</td><td>24kW</td></tr> <tr><td>Hot water capacity</td><td>30 - 80°C</td></tr> <tr><td>Pump speed</td><td>1400U/min</td></tr> <tr><td>Connected load</td><td>28,8kW/44,2A</td></tr> <tr><td>Electrical protection</td><td>3x50A träge</td></tr> </table> <p>Serial No.: 011110111 88894</p> <p>EHRLE GmbH   Industriestraße 3 D-89165 Dietenheim              Tel.: 0 73 03 / 16 00-0   Fax: 0 73 03 / 16 00-600</p>	Voltage	3/N/PE/AC/400-415V/50Hz	Operating pressure	30-130bar/3-13MPa	Max. pressure	150bar/15MPa	Discharge capacity	300 - 720l/h	Nozzle size	045	Heating power	24kW	Hot water capacity	30 - 80°C	Pump speed	1400U/min	Connected load	28,8kW/44,2A	Electrical protection	3x50A träge	<p><b>HSC1140-INOX 30kW</b></p> <p>Type: HSC1140-INOX 30kW 533-XX-B </p> <table border="1" style="width: 100%; border-collapse: collapse;"> <tr><td>Voltage</td><td>3/N/PE/AC/50Hz/400V</td></tr> <tr><td>Operating pressure</td><td>30-165bar/3-16,5MPa</td></tr> <tr><td>Max. pressure</td><td>185bar/18,5MPa</td></tr> <tr><td>Discharge capacity</td><td>300 - 1000l/h</td></tr> <tr><td>Nozzle size</td><td>055</td></tr> <tr><td>Heating power</td><td>30kW</td></tr> <tr><td>Hot water capacity</td><td>30 - 80°C</td></tr> <tr><td>Pump speed</td><td>1400U/min</td></tr> <tr><td>Connected load</td><td>36,5kW/57,0A</td></tr> <tr><td>Electrical protection</td><td>3x63A träge</td></tr> </table> <p>Serial No.: 001011000 88894</p> <p>EHRLE GmbH   Industriestraße 3 D-89165 Dietenheim              Tel.: 0 73 03 / 16 00-0   Fax: 0 73 03 / 16 00-600</p>	Voltage	3/N/PE/AC/50Hz/400V	Operating pressure	30-165bar/3-16,5MPa	Max. pressure	185bar/18,5MPa	Discharge capacity	300 - 1000l/h	Nozzle size	055	Heating power	30kW	Hot water capacity	30 - 80°C	Pump speed	1400U/min	Connected load	36,5kW/57,0A	Electrical protection	3x63A träge
Voltage	3/N/PE/AC/400-415V/50Hz																																								
Operating pressure	30-130bar/3-13MPa																																								
Max. pressure	150bar/15MPa																																								
Discharge capacity	300 - 720l/h																																								
Nozzle size	045																																								
Heating power	24kW																																								
Hot water capacity	30 - 80°C																																								
Pump speed	1400U/min																																								
Connected load	28,8kW/44,2A																																								
Electrical protection	3x50A träge																																								
Voltage	3/N/PE/AC/50Hz/400V																																								
Operating pressure	30-165bar/3-16,5MPa																																								
Max. pressure	185bar/18,5MPa																																								
Discharge capacity	300 - 1000l/h																																								
Nozzle size	055																																								
Heating power	30kW																																								
Hot water capacity	30 - 80°C																																								
Pump speed	1400U/min																																								
Connected load	36,5kW/57,0A																																								
Electrical protection	3x63A träge																																								

#### 3.2.2 Series HSC-Electric INOX FR

<p><b>HSC840-INOX FR 24kW</b></p> <p>Type: HSC840-INOX FR 24kW 531001-XX-B </p> <table border="1" style="width: 100%; border-collapse: collapse;"> <tr><td>Voltage</td><td>3/N/PE/AC/400-415V/50Hz</td></tr> <tr><td>Operating pressure</td><td>30-130bar/3-13MPa</td></tr> <tr><td>Max. pressure</td><td>150bar/15MPa</td></tr> <tr><td>Discharge capacity</td><td>300 - 720l/h</td></tr> <tr><td>Nozzle size</td><td>045</td></tr> <tr><td>Heating power</td><td>24kW</td></tr> <tr><td>Hot water capacity</td><td>30 - 80°C</td></tr> <tr><td>Pump speed</td><td>1400U/min</td></tr> <tr><td>Connected load</td><td>28,8kW/44,2A</td></tr> <tr><td>Electrical protection</td><td>3x50A träge</td></tr> </table> <p>Serial No.: 011110111 88894</p> <p>EHRLE GmbH   Industriestraße 3 D-89165 Dietenheim              Tel.: 0 73 03 / 16 00-0   Fax: 0 73 03 / 16 00-600</p>	Voltage	3/N/PE/AC/400-415V/50Hz	Operating pressure	30-130bar/3-13MPa	Max. pressure	150bar/15MPa	Discharge capacity	300 - 720l/h	Nozzle size	045	Heating power	24kW	Hot water capacity	30 - 80°C	Pump speed	1400U/min	Connected load	28,8kW/44,2A	Electrical protection	3x50A träge	<p><b>HSC1140-INOX FR 30kW</b></p> <p>Type: HSC1140-INOX FR 30kW 533004-XX-B </p> <table border="1" style="width: 100%; border-collapse: collapse;"> <tr><td>Voltage</td><td>3/N/PE/AC/400-415V/50Hz</td></tr> <tr><td>Operating pressure</td><td>30-165bar/3-16,5MPa</td></tr> <tr><td>Max. pressure</td><td>185bar/18,5MPa</td></tr> <tr><td>Discharge capacity</td><td>300 - 1000l/h</td></tr> <tr><td>Nozzle size</td><td>055</td></tr> <tr><td>Heating power</td><td>30kW</td></tr> <tr><td>Hot water capacity</td><td>30 - 80°C</td></tr> <tr><td>Pump speed</td><td>1400U/min</td></tr> <tr><td>Connected load</td><td>36,5kW/57,0A</td></tr> <tr><td>Electrical protection</td><td>3x63A träge</td></tr> </table> <p>Serial No.: 101010111 88894</p> <p>EHRLE GmbH   Industriestraße 3 D-89165 Dietenheim              Tel.: 0 73 03 / 16 00-0   Fax: 0 73 03 / 16 00-600</p>	Voltage	3/N/PE/AC/400-415V/50Hz	Operating pressure	30-165bar/3-16,5MPa	Max. pressure	185bar/18,5MPa	Discharge capacity	300 - 1000l/h	Nozzle size	055	Heating power	30kW	Hot water capacity	30 - 80°C	Pump speed	1400U/min	Connected load	36,5kW/57,0A	Electrical protection	3x63A träge
Voltage	3/N/PE/AC/400-415V/50Hz																																								
Operating pressure	30-130bar/3-13MPa																																								
Max. pressure	150bar/15MPa																																								
Discharge capacity	300 - 720l/h																																								
Nozzle size	045																																								
Heating power	24kW																																								
Hot water capacity	30 - 80°C																																								
Pump speed	1400U/min																																								
Connected load	28,8kW/44,2A																																								
Electrical protection	3x50A träge																																								
Voltage	3/N/PE/AC/400-415V/50Hz																																								
Operating pressure	30-165bar/3-16,5MPa																																								
Max. pressure	185bar/18,5MPa																																								
Discharge capacity	300 - 1000l/h																																								
Nozzle size	055																																								
Heating power	30kW																																								
Hot water capacity	30 - 80°C																																								
Pump speed	1400U/min																																								
Connected load	36,5kW/57,0A																																								
Electrical protection	3x63A träge																																								

### 3.3 Serial number

The serial number on the nameplate uniquely identifies the product. It is required for Ehrle customer service.

Ser. Nr. \_\_\_\_\_

### 3.4 Technical data

#### 3.4.1 HSC840-INOX 24kW / HSC1140-INOX 30kW

		HSC840-INOX 24kW	HSC1140-INOX 30kW
<b>Performance data</b>			
Operating pressure	bar	30 - 130	30 - 165
	MPA	3 - 13	3 - 16,5
Max. operating over pressure (infinitely variable)	bar	150	185
	MPA	15	18,5
Discharge capacity	l/h	300 - 720	300 - 1000
Hot water capacity	° C	30 - 80	30 - 80
Electric boiler	l	65	65
Pump speed	rpm	1400	1400
Detergent suction max. (infinitely variabl)	l/h	28	19
Recoil force trigger gun	N	30,4	55,4
Nozzle size	---	045	055
<b>Electrical connection</b>			
Mains voltage	V	400	400
Phase	~	3	3
Mains frequency	Hz	50	50
Connected load	kW	28,8	36,5
Current (max.)	A	44,2	57
Heating capacity	kW	24	30
Electric heating chassis	W	80	80
Main fuse (slow blowing)	A	3 x 50	3 x 63
Residual current circuit breaker (max. allowed residual current)	mA	30	30
Degree of protection	-	IPX5	IPX5
Connection cable 7,5 m (H07 - RNF)	wires	5	5
	mm <sup>2</sup>	6	16

Tab. 3 - 1 Technical data HSC840-INOX 24kW / HSC1140-INOX 30kW

		<b>HSC840-INOX 24kW</b>	<b>HSC1140-INOX 30kW</b>
<b>Temperature values</b>			
Inlet temperature (max.)	° C	45	45
Ininitely variable	° C	30 - 80	30 - 80
with a heating capacity of	kW	24	30
<b>Water connection</b>			
Max. feed pressure	bar	5	5
	MPA	0,5	0,5
Max. feed temperature	° C	45	45
Feed volume	l/min	12	15
Suction height	m	0	0
<b>Weight and Dimensions</b>			
Weight (with packaging)	kg	264 (281)	292 (309)
Length (with packaging)	mm	1220 (1250)	1220 (1250)
Width (with packaging)	mm	755 (815)	755 (815)
Height (with packaging)	mm	1625 (1755)	1625 (1755)

Tab. 3 - 1 Technical data HSC840-INOX 24kW / HSC1140-INOX 30kW

### 3.4.2 HSC840-INOX FR 24kW / HSC1140-INOX FR 30kW

		HSC840-INOX FR 24kW	HSC1140-INOX FR 30kW
<b>Performance data</b>			
Operating pressure	bar	30 - 130	30 - 165
	MPA	3 - 13	3 - 16,5
Max. operating over pressure (infinitely variable)	bar	150	185
	MPA	15	18,5
Discharge capacity	l/h	300 - 720	300 - 1000
Hot water capacity	° C	30 - 80	30 - 80
Electric boiler	l	65	65
Pump speed	rpm	1400	1400
Detergent suction max. (infinitely variabl)	l/h	28	19
Recoil force trigger gun	N	30,4	55,4
Nozzle size	---	045	055
<b>Electrical connection</b>			
Mains voltage	V	400	400
Phase	~	3	3
Mains frequency	Hz	50	50
Connected load	kW	28,8	36,5
Current (max.)	A	44,2	57
Heating capacity	kW	24	30
Electric heating chassis	W	80	80
Main fuse (slow blowing)	A	3 x 50	3 x 63
Residual current circuit breaker (max. allowed residual current)	mA	30	30
Degree of protection	-	IPX5	IPX5
Connection cable 7,5 m (H07 - RNF)	wires	5	5
	mm <sup>2</sup>	6	16

Tab. 3 - 2 Technical data HSC840-INOX 24kW / HSC1140-INOX 30kW

		HSC840-INOX FR 24kW	HSC1140-INOX FR 30kW
<b>Temperature values</b>			
Inlet temperature (max.)	° C	45	45
Infinately variable	° C	30 - 80	30 - 80
with a heating capacity of	kW	24	30
<b>Water connection</b>			
Max. feed pressure	bar	5	5
	MPA	0,5	0,5
Max. feed temperature	° C	45	45
Feed volume	l/min	12	15
Suction height	m	0	0
<b>Weight and Dimensions</b>			
Weight (with packaging)	kg	264 (281)	292 (309)
Length (with packaging)	mm	1220 (1250)	1220 (1250)
Width (with packaging)	mm	755 (815)	755 (815)
Height (with packaging)	mm	1625 (1755)	1625 (1755)

Tab. 3 - 2 Technical data HSC840-INOX 24kW / HSC1140-INOX 30kW

### 3.5 Selection of spray nozzles

Contamination	Nozzle	Spraying angle	Article-No.	Pressure [MPa]
heavy	050 (blue)	25°	25050	max. 20

Tab. 3 - 3 List of spray nozzles

## 4 Installation



### WARNING

#### Ensure correct device assembly.

For the installation of the high pressure cleaners, the personnel must have

- read this manual and understood, that error-free device assembly can be guaranteed, or
- specially trained and instructed on the respective system.

Otherwise, the life and limb of persons may be endangered.



### WARNING

#### Danger with heavy loads.

The Stationary Hotwater High Pressure Cleaners of the Series HSC-Electric weigh 264 kg resp. 281 kg (with packaging 292 kg resp. 309 kg). Components of the high pressure cleaners can have a weight of more than 23 kg.

A person is not allowed to lift and move loads (e.g. devices, assemblies) more than 23 kg.

Otherwise the health of persons may be endangered (e.g. overload of the spinal column, injuries from falling loads).

For loads of more than 23 kg, use suitable lifting equipment (e.g. forklift, lift truck).



### General Information

For detailed advice and information on the installation of the Stationary Hotwater High Pressure Cleaners Series HSC-Electric, please contact EHRLE customer service.

If required, EHRLE customer service can commission appropriately qualified personnel to carry out a wide range of installation work.

### 4.1 Selection of the operating location



### WARNING

#### Select a suitable and permissible operating location for the system.

The local regulations concerning the installation and operation of the system must be observed.

The Stationary Hotwater High Pressure Cleaners must not be installed and operated in rooms or areas subject to fire or explosion hazards.

For use at petrol stations or similar hazardous areas, reference is made to the hazardous areas in accordance with the „Technical Rules for Flammable Liquids“ (TRGF).

Select a dry and operationally safe location for the system cabinet. The site of use must have a water drainage system

When selecting a location, take into account that the following plant components and the power supply must be easily accessible for operation,

maintenance, repair and adjustment work (for dimensions see also Fig. 4 - 1):

- cover maintenance opening (e.g. 6, Fig. 3 - 1)
- connections for system supply
  - supply voltage
  - water pipe
- the swivel area of the cabinet door must be completely free
- washing station equipment such as trigger gun and high pressure hose

The building water connection (mains water supply) and the electrical connection (mains connection) for supplying the system must be designed for trouble-free constant continuous operation (see also section 3.4, Techn. Data).

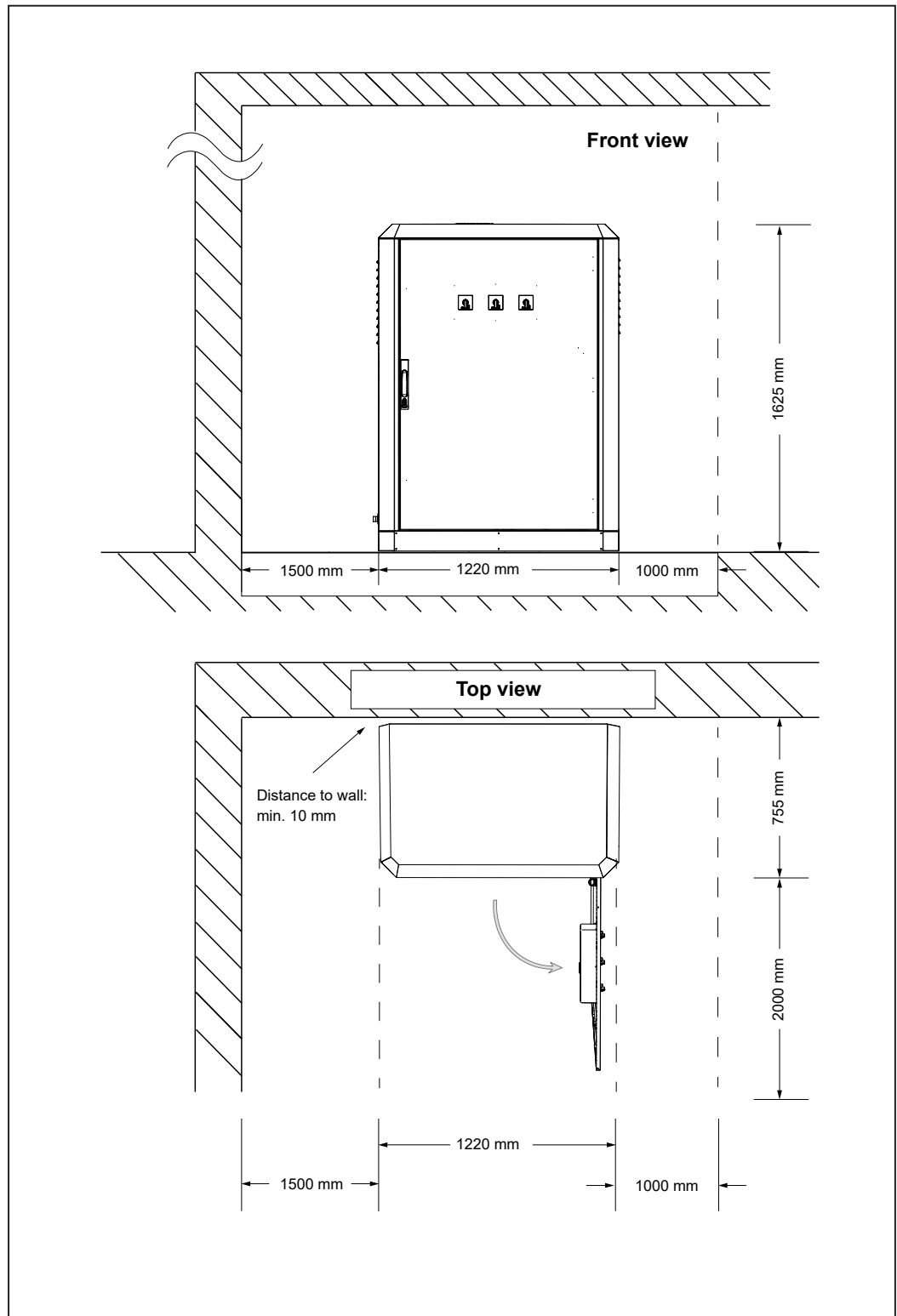

Fig. 4 - 1 Required dimensions for operating location, here in the example Series HSC-Electric INOX

## 4.2 Installation material



### General Information

The following illustration with table is a general example of a system configuration.

For comprehensive advice and information on customer-specific specific planning, configuration and installation of the system, EHRLE can be consulted at any time via customer service.

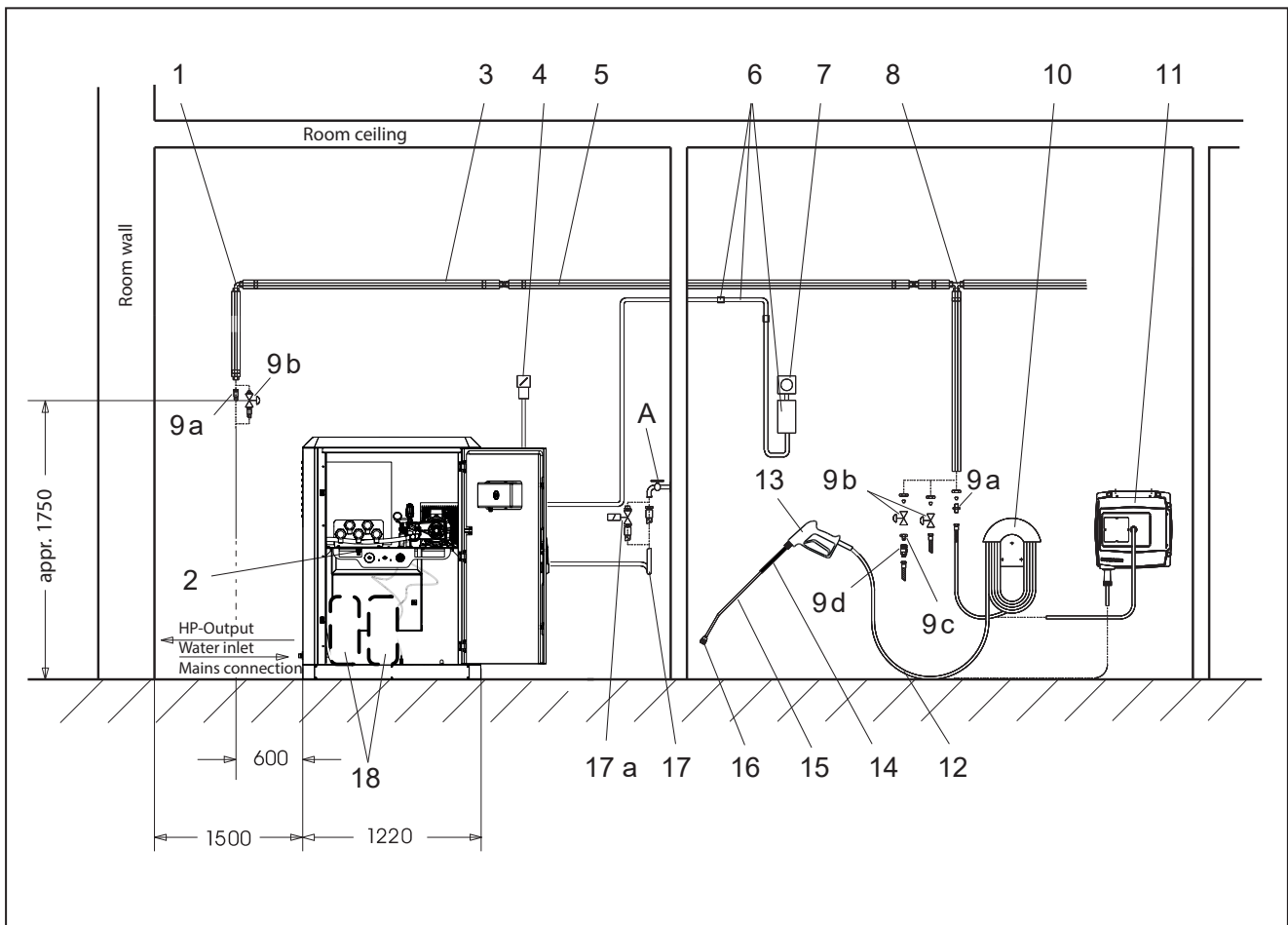

Fig. 4 - 2 Installation material for installation site inside buildings (general example)

<b>Position</b>	<b>Installation material</b>
1	Elbow screw fitting
2	Stopcock water drain (electrically heated boiler)
3	Thermal insulation
4	Main switch
5	HD piping kit
6	Remote control parts kit
7	Kit of parts emergency stop switch
8	T-fitting
9a	HD connection M22x1,5 brass HD connection M22x1,5 stainless steel
9b	Stopcock NW 8, galvanized steel Stopcock NW 8, stainless steel
9c	Quick coupling fixed part (high pressure)
9d	Quick coupling loose part (high pressure)
10	Hose holder
11	Hose reel (optionally for position 10)
12	HP-hose
13	Trigger gun
14	Spray lance holder (hand protection)
15	Spray lance
16	Nozzle mouthpiece
17	Water hose
17a	Solenoid valve water inlet
18	Detergent container 2 x 25 l

Tab. 4 - 1 List of installation material, general example

### 4.3 Installation of the electrical connection



#### WARNING

##### Ensure proper installation of the electrical connection.

The electrical connection may only be carried out by qualified, trained and authorised electrical specialists.

Observe the IEC-regulations for electrical cable laying.

All live parts in the intended working area for cleaning work, e.g. equipment, cables, sockets etc. must be protected against water jets in accordance with safety regulations.

Only connect the system to voltage sources earthed in accordance with the safety regulations.

The connection plugs must not lie on the floor and must always be dry. Do not touch the connectors with wet hands.

Improper installation of the electrical connection can endanger life and limb of persons.



#### General Information

When installing the cabinet of Series HSC-Electric INOX, the direction of rotation of the HP-pump motors does not have to be observed.

A right-hand rotating field is required for the frost protection pump in the HSC-Electric FR INOX series.

Have the electrical connection carried out by qualified and trained electricians. Ensure compliance with the provisions of IEC 60364-1.

The electrical mains connection (building connection) for the supply voltage of the system must be designed for trouble-free constant operation (see Section 3.4, Technical Data).

The electrical mains connection of the building must correspond to the electrical values given on the type plate of the system (see Section 3.4, Technical Data).

The following components of the building power supply must be installed at an easily accessible installation site:

- Socket for the plug of the power supply cable of the system.
- Building power supply on/off switch.
- Fuses or circuit breakers for the building power supply.

Install the electrical connections according to the system-specific circuit diagram (see section 10, Technical documents).



**WARNING**

**Danger of electric shock.**

Do not connect the system to the building power supply until all installation work has been completed.

For connection to the building network, proceed according to the instructions in section 5, Commissioning.

Otherwise, the life and limb of persons may be endangered.

Do not connect the system to the mains supply (building connection) until starting with commissioning in accordance with the instructions in section 5.2, First switch-on after installation.

## 4.4 Establishing the water connection



**CAUTION**

**Dirty water can damage the high pressure cleaner.**

Only operate the high pressure cleaner with clear and unpolluted water.

The building water connection (tap water network) for the water supply of the high pressure cleaner must be designed for trouble-free constant operation (see Section 3.4, Technical Data).

The water connection for the high pressure cleaner must ensure a water supply of 1500 l/h under a flow pressure between 1 bar and 6 bar.

The regulations of the relevant water supply company must be observed! According to EN 61 770, the system must not be directly connected to the public drinking water supply. However, according to DVGW (Deutscher Verband des Gas- und Wasserfaches - German Gas and Water Association), short-term connection is permissible if a backflow preventer with a pipe ventilator is installed in the supply line. Water after the backflow preventer is no longer considered drinking water.

An indirect connection to the public drinking water supply is also permissible by means of a free outlet. The water supply must comply with EN 61 770, e.g. by using a tank with a float valve. Direct connection to a pipe network not intended for drinking water supply is permissible.

The environmental, waste and water protection regulations must be observed by the system operator!

Equip the water connection of the tap water network with a shut-off valve.

Connect the high pressure cleaner to the water connection via a flexible pressure hose (at least 3/4").

## 4.5 Assembly of washing station equipment



### CAUTION

**Ensure that the high pressure hose is handled properly.**

Do not

- run vehicles over the high pressure hose,
- pull it excessively, twist or bend it
- run it over sharp-edged objects.

Otherwise the high pressure hose may be damaged.



### CAUTION

**Ensure pressure-tight screw connection of the washing station equipment.**

Leakage on screw connections of the trigger gun, pressure hose- or hose drum connection lead to increased wear and may damage system parts.

Rectify leakages immediately.

When assembling the washing station equipment, make sure that the individual parts are pressure-tight.

To assemble the wash station equipment, proceed as follows:

- ▶ Connect the high pressure hose to the socket (5, Fig. 6 - 2 for Series HSC-Electric resp. 4, Fig. 6 - 3 for Series HSC-Electric FR) of the trigger gun.
- ▶ Connect the other high pressure hose adapter to the high pressure hose connection of the high pressure cleaner (different connection depending on system type).
- ▶ For HSC840-INOX 24kW / HSC1140-INOX 30kW, attach the HP-nozzle with spray lance to the trigger gun.  
For HSC840-INOX FR 24kW / HSC1140-INOX FR 30kW, attach the HP-nozzle to the lance that is firmly connected to the switch-off gun.

## 4.6 Setting up the detergent container



### General Information

The supply of chemicals and cleaning agents is controlled by standard built-in solenoid valves. This prevents uncontrolled overflow of the cleaning agent into the float container or back into the cleaning detergent container.

Two detergent containers, each with a capacity of 25 l, can be placed inside the cabinet for the supply of detergent.

Place the two plastic containers in the location provided by the manufacturer inside the cabinet (see Fig. 4 - 3 to Fig. 4 - 6).

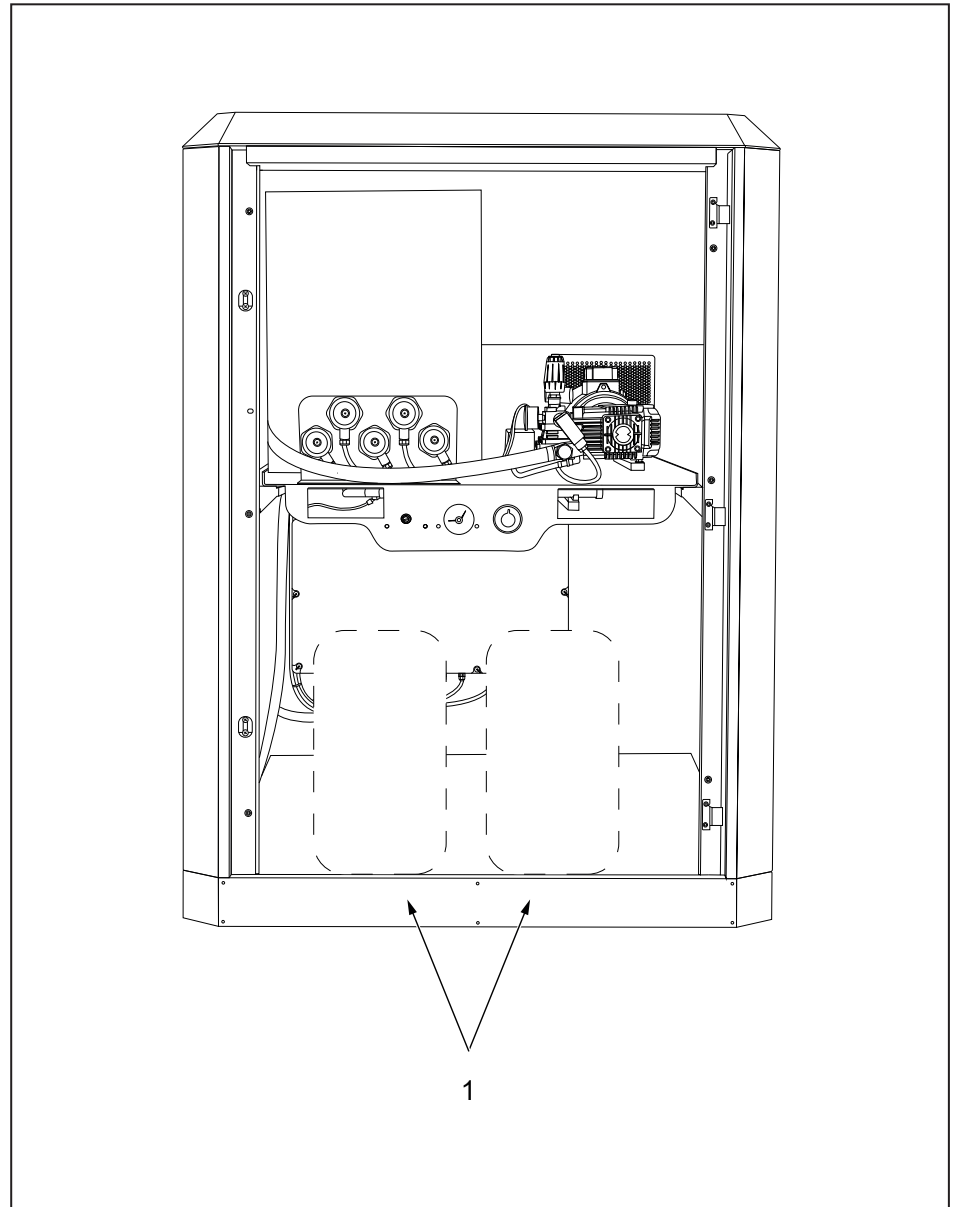

1 Detergent containers 25 l

Fig. 4 - 3 Location of detergent containers 25 l for Series HSC-Electric INOX

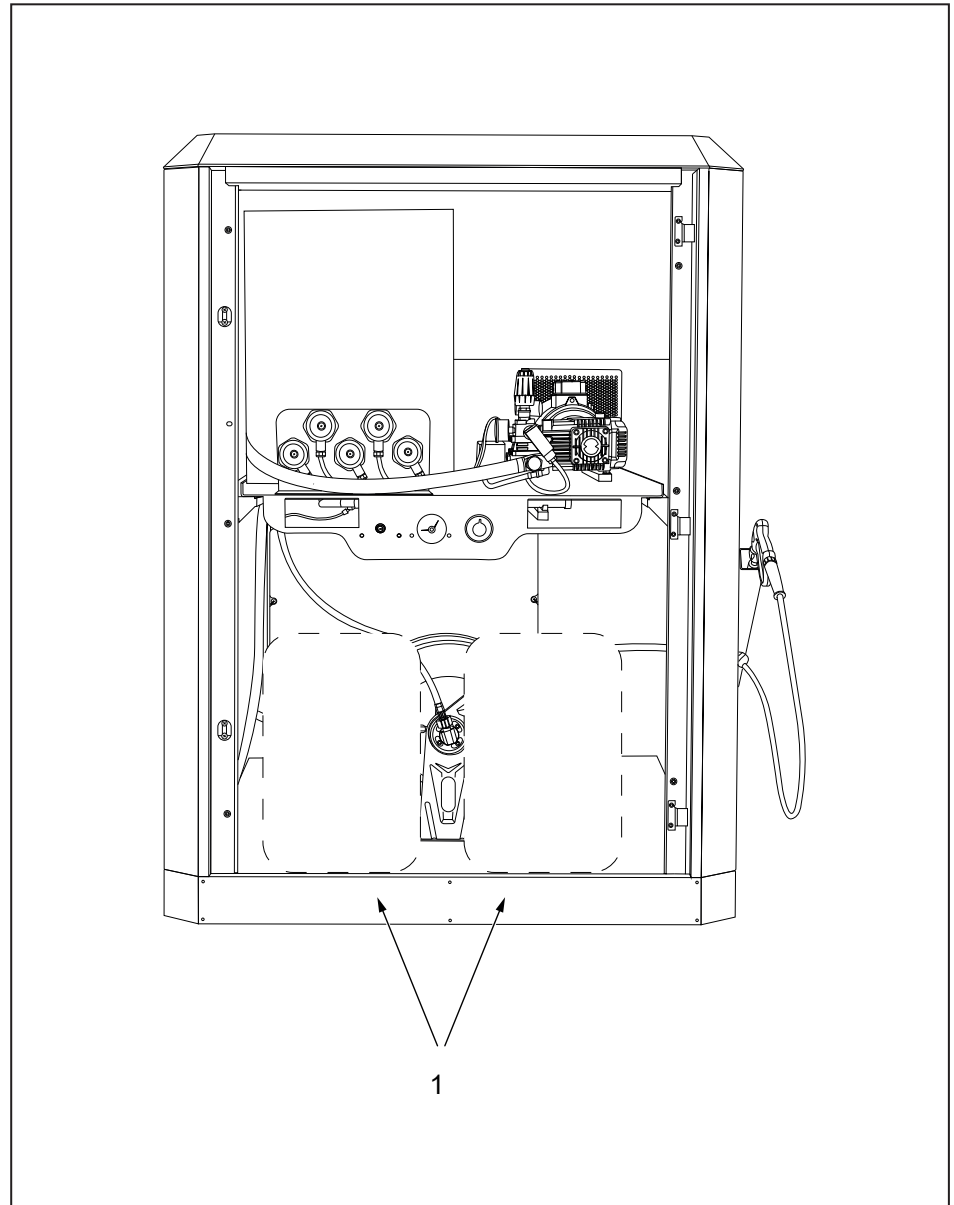

1 Detergent containers 25 l

Fig. 4 - 4 Location of detergent containers 25 l for Series HSC-Electric INOX, with optional kit 265300

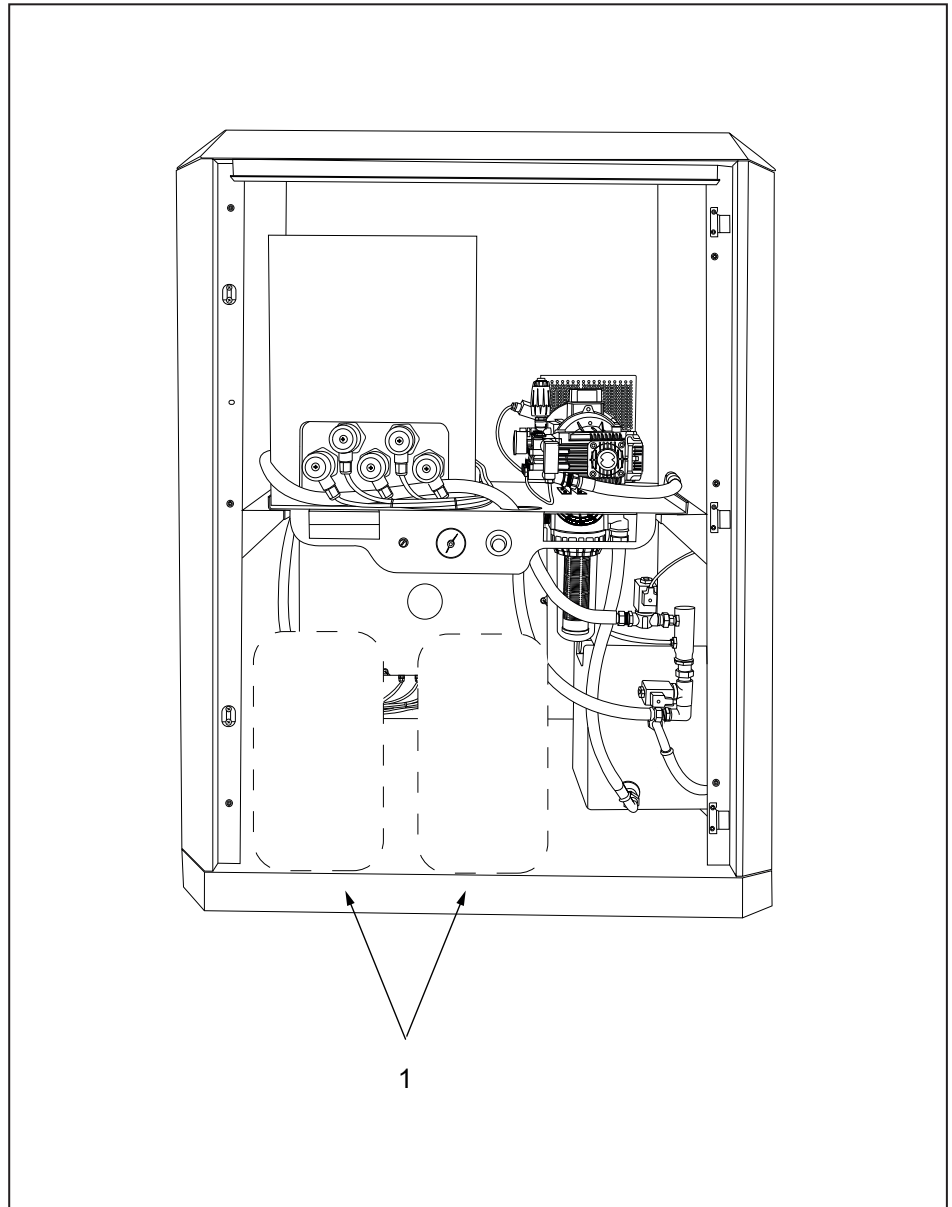

1 Detergent containers 25 l

Fig. 4 - 5 Location for detergent container for Series HSC-Electric INOX FR

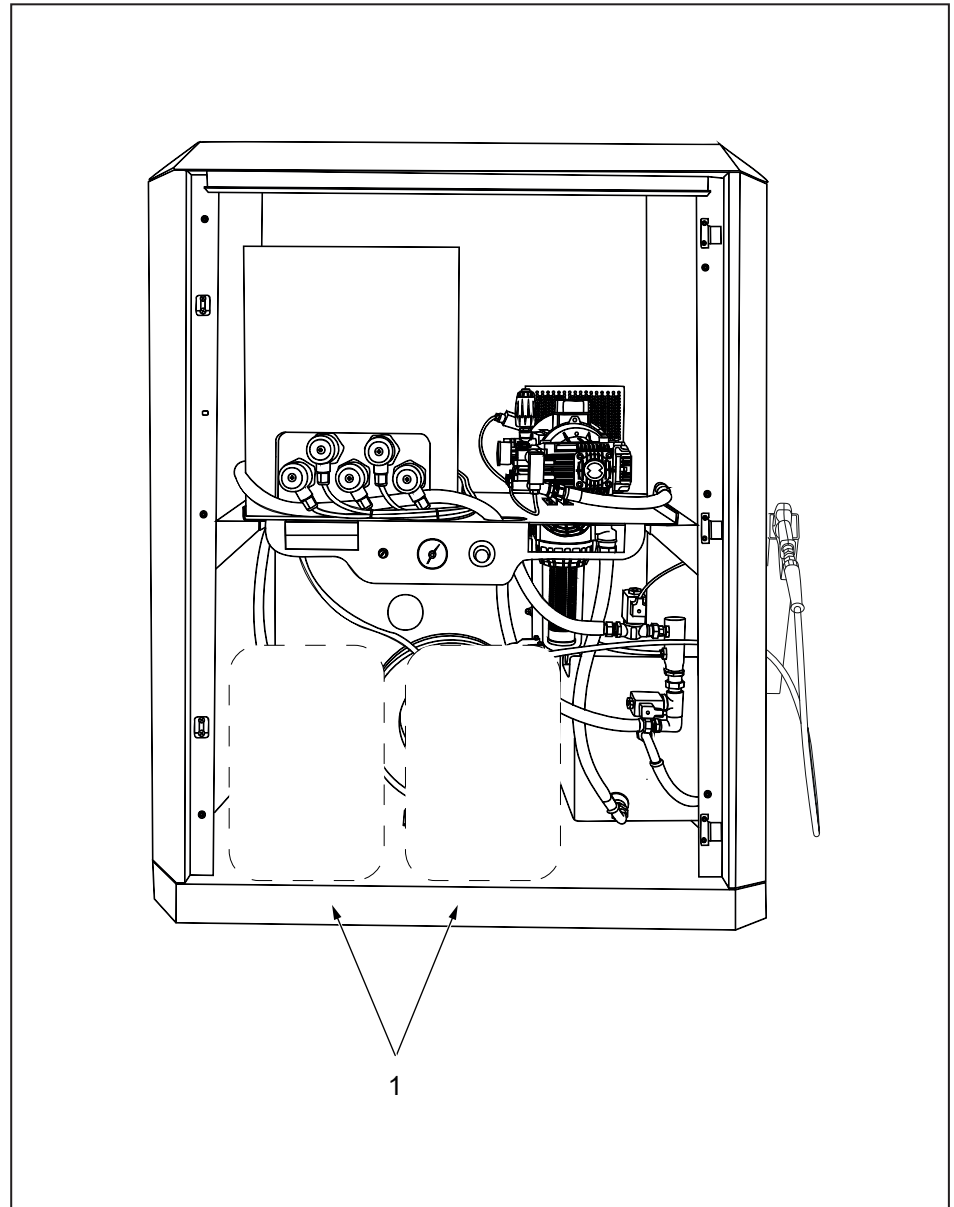

1 Detergent containers 25 l

Fig. 4 - 6 Location of detergent containers 25 l for Series HSC-Electric INOX FR, with optional kit 265300

## 5 Commissioning



### WARNING

#### Carry out initial commissioning professionally.

The measures for initial commissioning may only be carried out by qualified, trained and authorised personnel.

### 5.1 Measures prior to commissioning

Proceed as follows before the initial commissioning:

- ▶ Check the oil level on the dipstick of the high pressure pump and top up to the „max.“ mark if necessary.

### 5.2 First switch-on after installation



### WARNING

#### Danger of electric shock.

In the event of accidents (e.g. due to life-threatening voltages) involving persons or to prevent accidents, switch off the system (see Section 6.4, EMERGENCY STOP - Switching off in the event of danger).

The water jet emerging from the trigger gun must not be directed at live electrical components or systems (machines, devices, lines, sockets, etc.).

Before cleaning, disconnect the electrical systems, modules or components from the power supply.



### WARNING

#### Risk of burns from hot surfaces or hot water.

During operation, the surfaces of system parts, assemblies or components can become hot (non-insulated pipes, metal parts of the trigger gun and spray lance, heated water, etc.). Touching hot surfaces or hot water can cause skin burns or scalds to people.

Ensure that the system parts, assemblies or components as well as cleaning objects have cooled down before starting operating, maintenance or repair work.

Proceed as follows for the initial commissioning of the system:

- ▶ If necessary, switch off the following system functions on the front of the cabinet door via the three main switches for the Series HSC-Electric INOX or the push-buttons for the Series HSC-Electric FR INOX (see also Fig. 6 - 1:
  - Start - Stop
  - Hot water
  - Detergent

this means that the three main switches on the HSC-Electric INOX series must be set to 0 resp.

for the HSC-Electric INOX FR series, press the relevant button if necessary when the button lighting is on. The three button lights must be off.

- ▶ Open the water supply from the tap water network via the shut-off tap.
- ▶ Connect the system with the power supply cable to the electrical mains connection of the building.
- ▶ Switch on the power supply via the circuit breaker on the building side.
- ▶ If necessary, unlock and open the cabinet door with the key
- ▶ Inside the cabinet, first set the thermostat (5, Fig. 6 - 4 for Series HSC-Electric resp. 5, Fig. 6 - 5) to the „Off“ position



#### WARNING

##### **Before activating, hold the trigger gun and the spray lance tightly.**

After activation of the trigger gun the emerging water jet exerts a jerky recoil force (see also Fig. 6 - 7).

This may result in unintentional jerking away from the selected cleaning object or the trigger gun slipping out of the hand, endangering the life and limb of persons

- ▶ Unlock and pull the trigger lever (3, Fig. 6 - 2 for Series HSC-Electric, resp. 2, Abb. 6 - 3 for Series HSC-Electric FR) of the trigger gun.
- ▶ On the front of the cabinet door:
  - for Series HSC-Electric: set the main switch Start - Stop (1, Fig. 6 - 1) to position 1.
  - for Series HSC-Electric FR: press the push-button Start - Stop (1, Fig. 6 - 1). The push-button light is on.

The high pressure cleaner starts. The pump first delivers air from the high pressure nozzle. After a short time, water then escapes.



#### WARNING

##### **Risk of scalding due to hot water.**

The hot water escaping from the spray lance must not come into contact with persons.

Otherwise scalding to persons may occur.

- ▶ Set the Thermostat (5, Fig. 6 - 4 for Series HSC-Electric, resp. 5, Fig. 6-5 for Series HSC-Electric FR) inside the cabinet to the desired temperature.
- ▶ On the front of the cabinet door:
  - for Series HSC-Electric: set the main switch Hot Water (2, Fig. 6 - 1) to position 1.
  - for Series HSC-Electric FR: press the push-button Hot Water (2, Fig. 6 - 1). The push-button light is on.

- ▶ Set the unloader valve (3, Fig. 6 - 4 for Series HSC-Electric, resp. 3, Fig. 6-5 for Series HSC-Electric FR) inside the cabinet to the desired operating pressure.
- ▶ The operating pressure can be read off the pressure gauge (2, Fig. 6 - 4 for Series HSC-Electric, resp. 2, Fig. 6 - 5 for Series HSC-Electric FR) while the trigger gun is activated.  
By turning the unloader valve (see Fig. 6 - 6) clockwise, the operating pressure and water quantity on the high pressure pump will increase.  
Turning counterclockwise results in lower working pressure and reduced water quantity.
- ▶ If the trigger lever on the trigger gun is released, the high pressure cleaner switches to pressureless circulation operation. After 20 sec. circulation mode switches the system to stand-by mode. When the lever on the trigger gun is pulled again, the motor and the pump restart automatically.



### **General Information**

If the system remains in stand-by mode for 20 minutes, the electronic control switches the high pressure cleaner off as programmed.

To resume operation

- ▶ for Series HSC-Electric set the main switch Start - Stop to position 0 and then back to operating position 1
- ▶ for Series HSC-Electric FR press the push-button Start - Stop. The push-button light is on.

- ▶ For safety reasons after completion of cleaning work
  - Lock the trigger lever of the trigger gun against unintentional switching on using the locking lever (4, Fig. 6 - 2 for Series HSC-Electric resp. 3, Fig. 6 - 3 for Series HSC-Electric FR). Ensure that the locking lever is positioned in the notch (6, Abb. 6 - 2 for Series HSC-Electric, resp. 5, Fig. 6 - 3 for Series HSC-Electric FR).
- ▶ On the front of the cabinet door
  - for Series HSC-Electric: set the main switch Start - Stop (1, Fig. 6 - 1) to position 0. The system is switched off.
  - for Series HSC-Electric FR: press the push-button Start - Stop (1, Fig. 6 - 1). The push-button light is off. The system is switched off.



### **General Information**

For the addition of detergents to the high pressure jet, see Section 6.7, Use of Detergents (Chemistry).

Only qualified personnel authorised by the system operator can set and specify the quantity of cleaning agent to be added inside the cabinet via the detergent control valve.

On the front of the cabinet door, the admixture of the cleaning agent can only be switched on/off.

## 6 Operation

### 6.1 System indicator and control elements

#### 6.1.1 Control elements on the cabinet front door

The following figure shows the control elements on the front of the cabinet door.

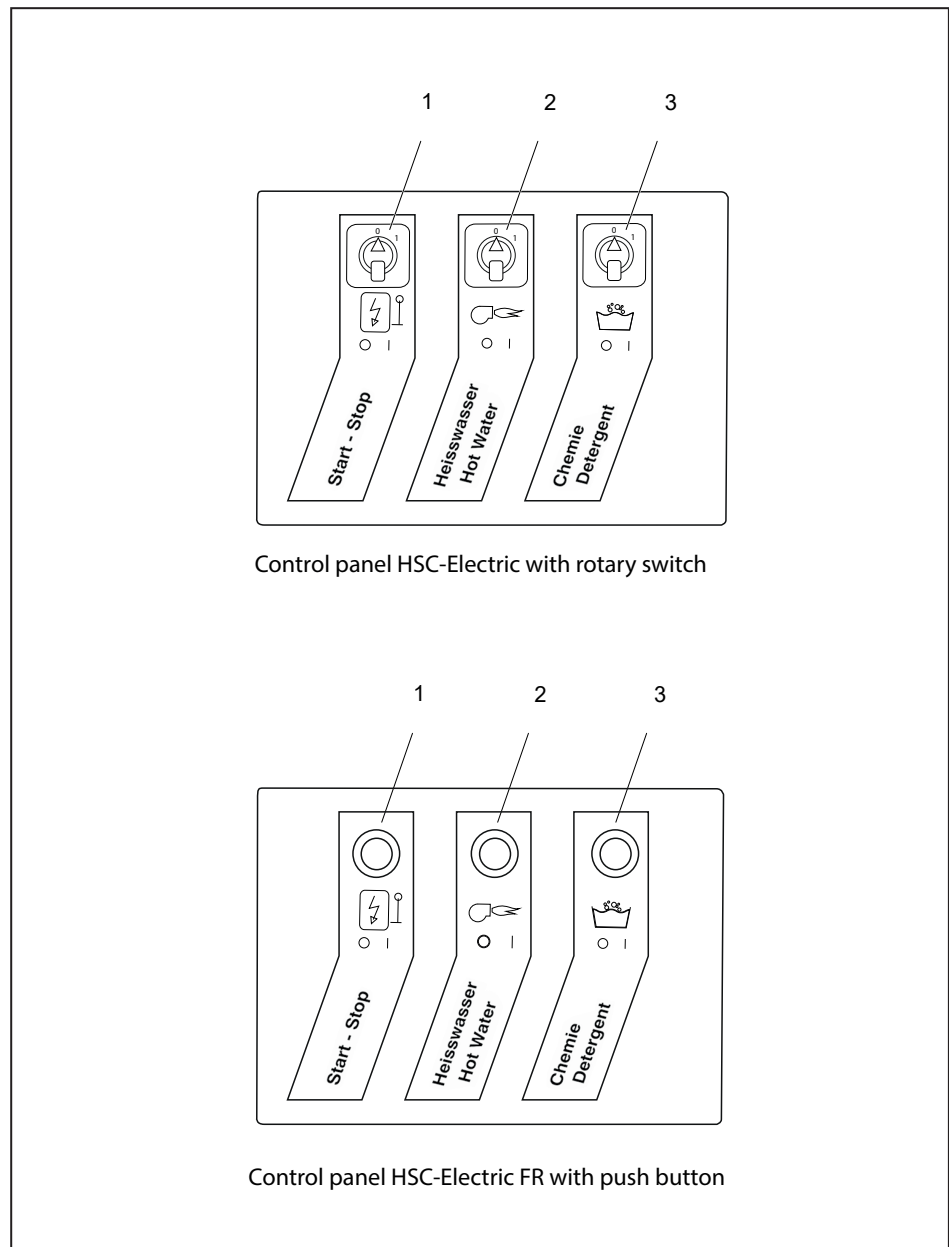

- 1 Main switch (resp. push-button Series HSC-Electric FR): Start - Stop
- 2 Main switch (resp. push-button Series HSC-Electric FR): Hot Water On/Off
- 3 Main switch (resp. push-button Series HSC-Electric FR): Detergent On/Off

Fig. 6 - 1 Control elements, cabinet front door

### 6.1.2 Control elements of the trigger gun

The two figures below show the control elements of the trigger gun for Series HSC-Electric and Series HSC-Electric FR.

For Series HSC-Electric, to assemble (disassemble) the spray lance to the (from) trigger gun see arrows in the figure below

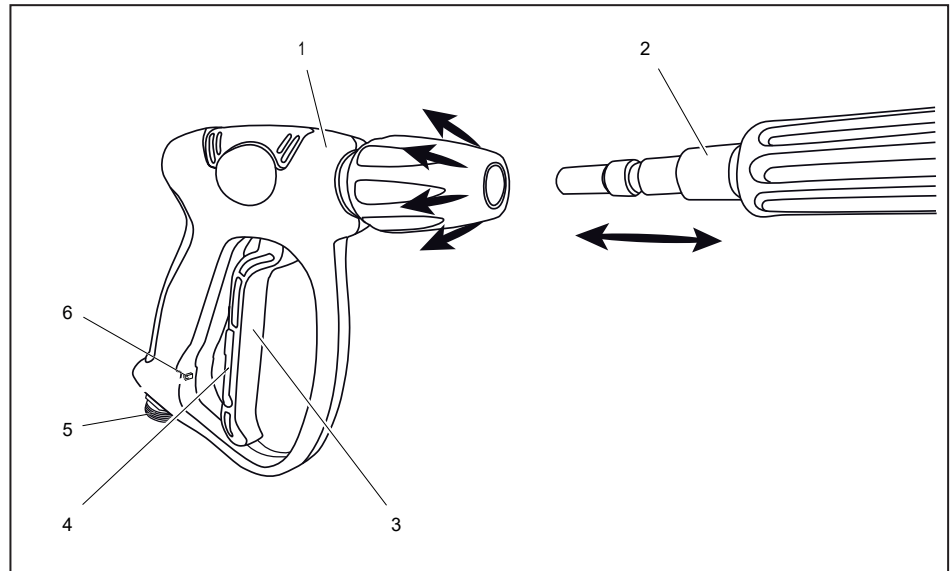

- |   |               |   |  |
|---|---------------|---|--|
| 1 | Trigger gun   | 4 | Locking lever (safety device)              |
| 2 | Spray lance   | 5 | Socket for HP-Hose                         |
| 3 | Trigger lever | 6 | Notch for locking lever (safety arresting) |

Fig. 6 - 2 Control elements for Series HSC-Electric

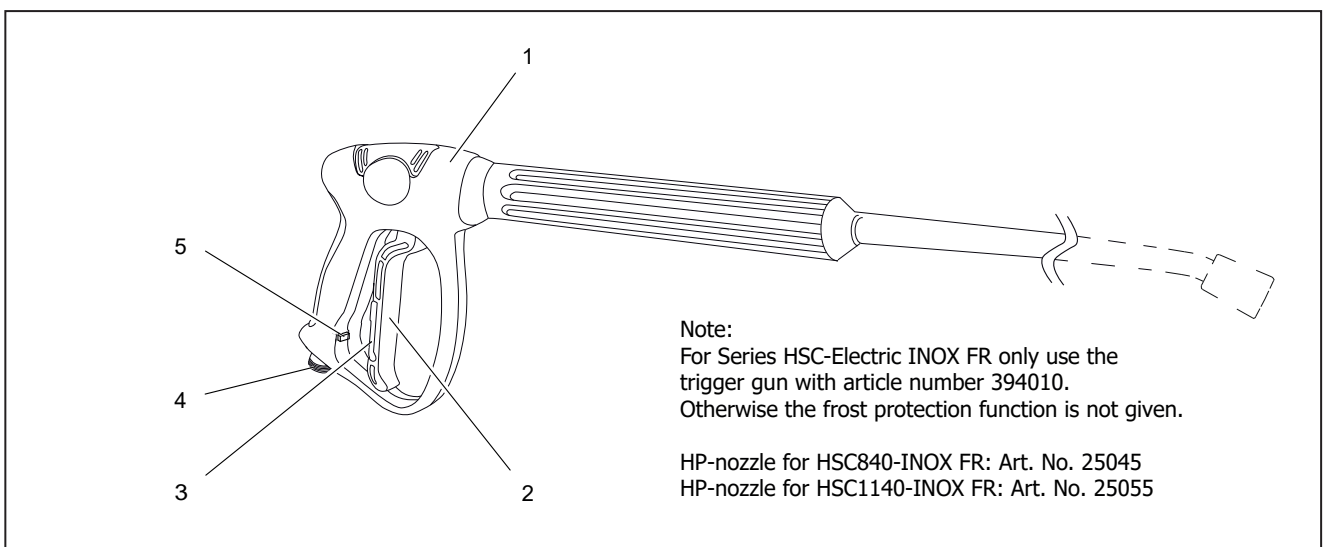

- |   |                               |   |  |
|---|-------------------------------|---|--|
| 1 | Trigger gung with spray lance | 4 | Socket for HP-Hose                         |
| 2 | Trigger lever                 | 5 | Notch for locking lever (safety arresting) |
| 3 | Locking lever (safety device) |   |  |

Fig. 6 - 3 Control elements of the trigger gun Series HSC-Electric FR

### 6.1.3 Control and indicator elements in the cabinet

The following figure shows the control and indicator elements inside the cabinet for Series HSC-Electric INOX.

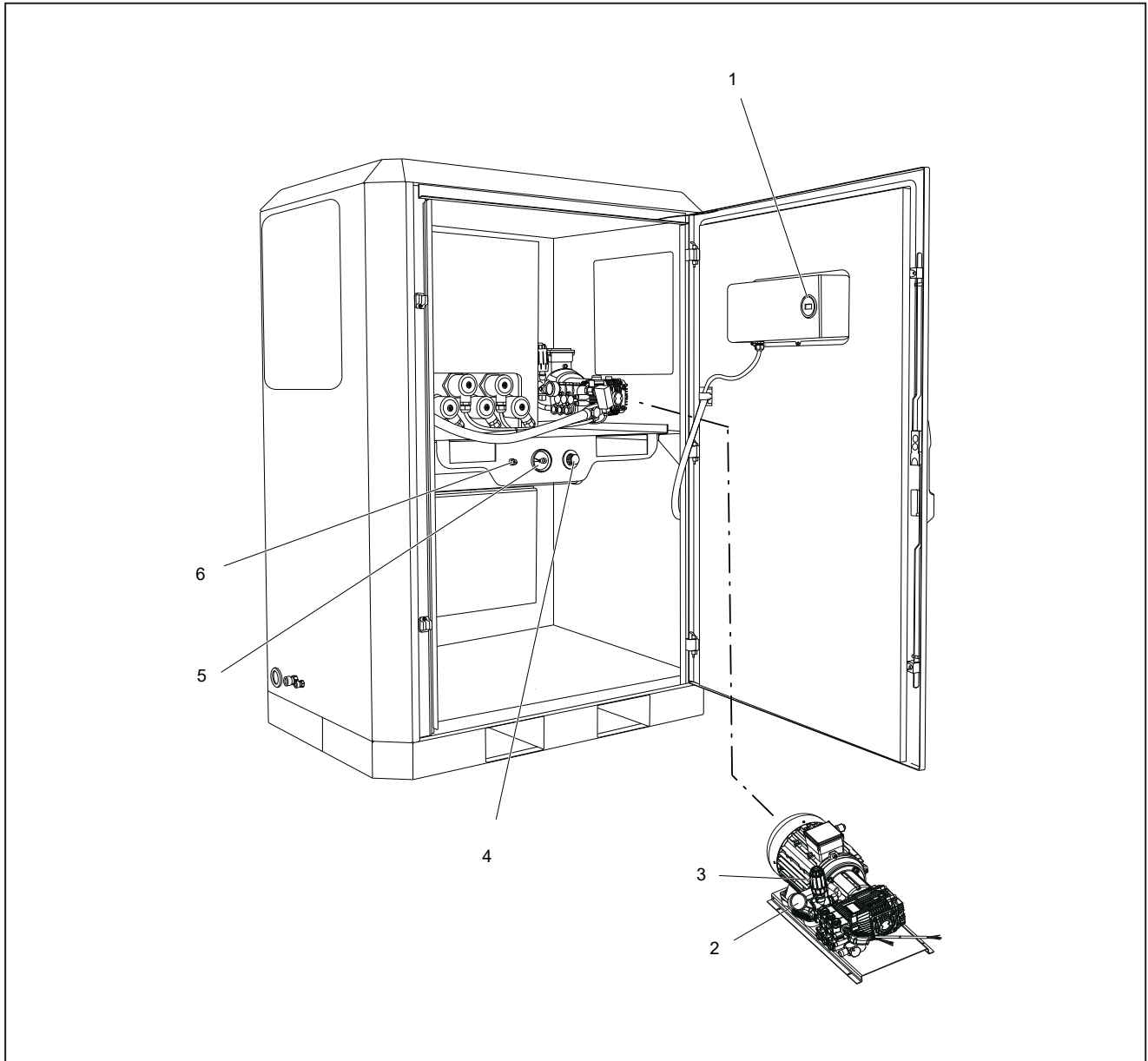

- |   |  |   |   |
|---|--|---|---|
| 1 | Service hour meter   | 4 | Detergent control valve   |
| 2 | Pressure gauge   | 5 | Thermostat (water temperature setting)                            |
| 3 | Unloader valve (variable pressure and quantity regulation) | 6 | Maximum Thermostat 95 °C (can be reset manually after triggering) |

Fig. 6 - 4 Stationary Hotwater High Pressure Cleaner Series HSC-Electric INOX, control and indicator elements (cabinet interior)

The following figure shows the control and indicator elements inside the cabinet for Series HSC-Electric INOX FR.

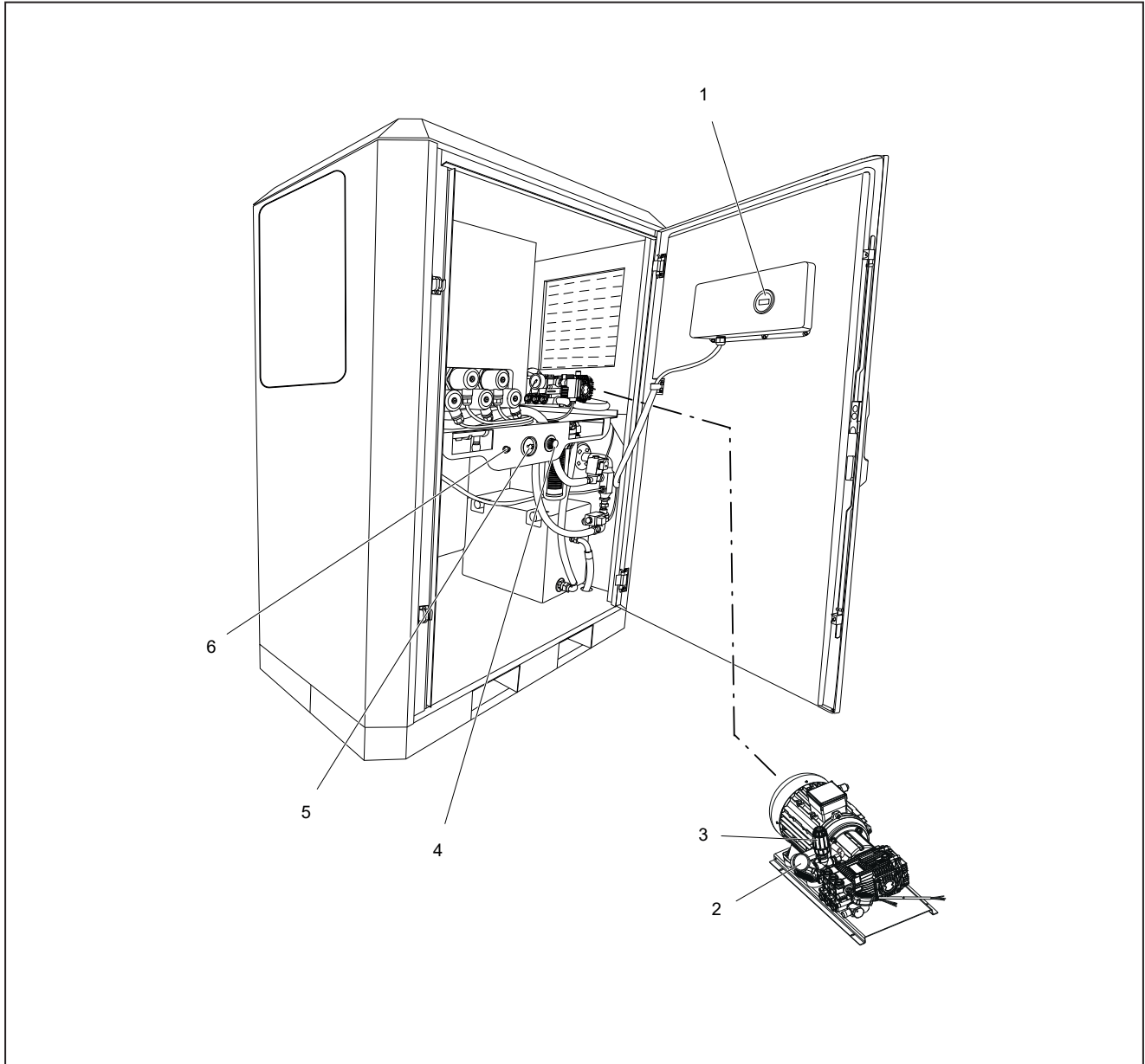

- |   |  |   |   |
|---|--|---|---|
| 1 | Service hour meter   | 4 | Detergent control valve   |
| 2 | Pressure gauge   | 5 | Thermostat (water temperature setting)                            |
| 3 | Unloader valve (variable pressure and quantity regulation) | 6 | Maximum Thermostat 95 °C (can be reset manually after triggering) |

Fig. 6 - 5 Stationary Hotwater High Pressure Cleaner Series HSC-Electric INOX FR, control and indicator elements (cabinet interior)

## 6.2 Measures for system operators before operation



### WARNING

#### Perform measures by the system operator in a professional manner.

The measures for system operators prior to operation may only be carried out by authorised, trained and qualified personnel.

Before operation or at periodic intervals (see Section 8, Maintenance), proceed as follows for all system types:

- ▶ Check the oil level on the dipstick of the high pressure pump and top up to the „max.“ mark if necessary.

## 6.3 Notes on operation for specialist and operating personnel



### WARNING

#### Ensure proper operation.

The system may only be adjusted and operated by qualified, trained personnel authorised by the system operator.



### WARNING

#### Danger of electric shock.

In the event of accidents (e.g. due to life-threatening voltages) involving persons or to prevent accidents, switch off the system (see Section 6.4, EMERGENCY STOP - Switching off in the event of danger).

The water jet emerging from the trigger gun must not be directed at live electrical components or systems (machines, devices, lines, sockets, etc.).

Before cleaning, disconnect the cleaning objects such as electrical systems, assemblies or components from the power supply.



### WARNING

#### Ensure that the high pressure jet is used correctly.

The water jet coming out of the trigger gun must not be directed at persons or animals.

In the event of accidents (e.g. danger to persons, injured persons in the work area) or to prevent accidents, switch off the system (see Section 6.4, EMERGENCY STOP - Switching off in the event of danger).



**WARNING**

**Risk of burns from hot surfaces or water.**

During operation, the surfaces of system parts, assemblies or components can become hot (e.g. non-insulated pipes, metal parts of the trigger gun and spray lance, heated water, etc.). Contact with hot surfaces or hot water can cause skin burns or scalding in persons.

Ensure that the system parts, assemblies or components as well as cleaning objects have cooled down before starting maintenance or repair work.

The design of the system distinguishes between two levels of access:

• **Level 1:**

Skilled personnel authorised by the system operator to set system parameters and operation (see section 6.5, System setting and operation for skilled personnel):

- Access to the control and indicator elements inside the cabinet via a lockable door.
- Adjustment of the desired operating parameters via the control elements inside the cabinet for:
  - Operating pressure
  - Water temperature
  - Quantity of water
  - Detergent additive.
- Switching on the system functions via the following main switches (for Series HSC-Electric) or push-buttons (for Series HSC-Electric FR) on the control panel on the front of the cabinet door
  - Start - Stop:                    On - Off
  - Hot Water:                        On - Off
  - Detergent:                        On - Off

• **Level 2:**

Operating personnel for carrying out cleaning work (see Section 6.6, System operation for operating personnel) with access for main switches (Series HSC-Electric) resp. push-buttons (Series HSC-Electric FR) on the front door:

- Switching on the system functions via the following main switches (for Series HSC-Electric) resp. push-buttons (for Series HSC-Electric FR):
  - Start - Stop:                    On - Off
  - Hot Water:                        On - Off
  - Detergent:                        On - Off

## 6.4 EMERGENCY STOP - switch-off in case of danger



### WARNING

**In case of electrical accidents, never directly touch persons exposed life-threatening voltages.**

In the event of accidents with persons at life-threatening voltages, immediately switch off the supply voltage to the high pressure cleaner or disconnect the power supply cable from the infrastructure mains plug. If possible, switch off the circuit breaker for the mains voltage.

Never touch the exposed person who has been involved in an accident directly. First aiders are also endangered by electric shock if they touch the person directly, in wet areas or over wet objects.

In extreme emergencies, without touching the injured person, use a dry garment, wooden slat or other insulating material to separate the person and mains voltage.

In case of accidents with persons or for accident prevention during device operation, perform an EMERGENCY STOP switch-off as follows:

- ▶ Switch off the high pressure cleaner as follows
  - for Series HSC-Electric set the main switch Start - Stop (1, Abb. 6 - 1) to position 0
  - for Series HSC-Electric FR press the push-button - Stop (1, Abb. 6 - 1). The push-button light is off.
- ▶ If necessary, if persons are still exposed to electric shock, switch off the power supply to the system via the circuit breaker (building connection) or disconnect the power supply cable from the mains socket.
- ▶ If necessary, activate the trigger gun until the high pressure cleaner is depressurised.
- ▶ Close shut-off valve for water supply (water mains) if necessary.

## 6.5 System setting and operation for skilled personnel



### General Information

Only qualified personnel authorised by the system operator may make settings inside the cabinet. This requires access to the key for opening the cabinet door.

For operation and system setting by authorised personnel, proceed as follows:

- ▶ If necessary, switch off the following system functions on the front of the cabinet door via the three main switches (Series HSC-Electric) resp. the push-buttons (Series HSC-Electric FR), see also Fig. 6 - 1:
- ▶ If necessary, switch off the following system functions on the front of the cabinet door via the three main switches (Series HSC-Electric) resp. the push-buttons (Series HSC-Electric FRI), see also Fig. 6 - 1:

- Start - Stop
- Hot Water
- Detergent

for Series HSC-Electric: if necessary set the three main switches to position 0 resp.

for Series HSC-Electric FR: If necessary press the push-buttons, if the push-button light is on. The push-button lights must be off.

- ▶ Open the shut-off valve of the tap water network.
- ▶ Connect the system to the electrical mains connection of the building using the power supply cable.
- ▶ Switch on the power supply via the circuit breaker resp. main switch on the building side.
- ▶ Unlock and open the cabinet door with the key.
- ▶ Inside the cabinet, set the thermostat (5, Fig. 6 - 4 for Series HSC-Electric, resp. 5, Fig. 6 - 5 for Series HSC-Electric FR) for setting the water temperature to the „Off“ position.



#### WARNING

##### **Before activating, hold the trigger gun and the spray lance tightly.**

After activation of the trigger gun the emerging water jet exerts a jerky recoil force (see also Fig. 6 - 7).

This may result in unintentional jerking away from the selected cleaning object or the trigger gun slipping out of the hand, endangering the life and limb of persons.

- ▶ Unlock and pull the trigger lever (3, Fig. 6 - 2 for Series HSC-Electric, resp. 2, Fig. 6 - 3 for Series HSC-Electric FR) of the trigger gun.
- ▶ On the front of the cabinet door
  - for Series HSC-Electric: set the main switch Start - Stop (1, Fig. 6 - 1) to position 1.
  - for Series HSC-Electric FR: press the push-button Start - Stop (1, Fig. 6 - 1). The push-button light is on.

The high pressure cleaner starts. The pump first delivers air from the HP-nozzle. After a short time, water then escapes.



#### WARNING

##### **Risk of scalding due to hot water.**

The hot water escaping from the high pressure jet must not come into contact with persons. Otherwise scalding may occur in persons.

- ▶ Inside the cabinet, set the Thermostat (5, Fig. 6 - 4 for Series HSC-Electric, resp. 5, Fig. 6-5 for Series HSC-Electric FR) to the desired temperature.
- ▶ On the front of the cabinet door
  - for Series HSC-Electric: set the main switch Hot Water (2, Fig. 6 - 1) to position 1.

- for Series HSC-Electric FR: press the push-button Hot Water (2, Fig. 6 - 1). The push-button light is on.
- ▶ The operating pressure can be read off the pressure gauge (2, Fig. 6 - 4 for Series HSC-Electric, resp. 2, Fig. 6 - 5 for Series HSC-Electric FR) while the trigger gun is activated.  
By turning the unloader valve (see Fig. 6 - 6) clockwise, the operating pressure and water quantity on the high pressure pump will increase. Turning counterclockwise results in lower working pressure and reduced water quantity.
- ▶ If the trigger lever on the trigger gun is released, the high pressure cleaner switches to pressureless circulation operation. After 20 sec. circulation mode switches the system to stand-by mode. When the lever on the trigger gun is pulled again, the motor and the pump restart automatically.

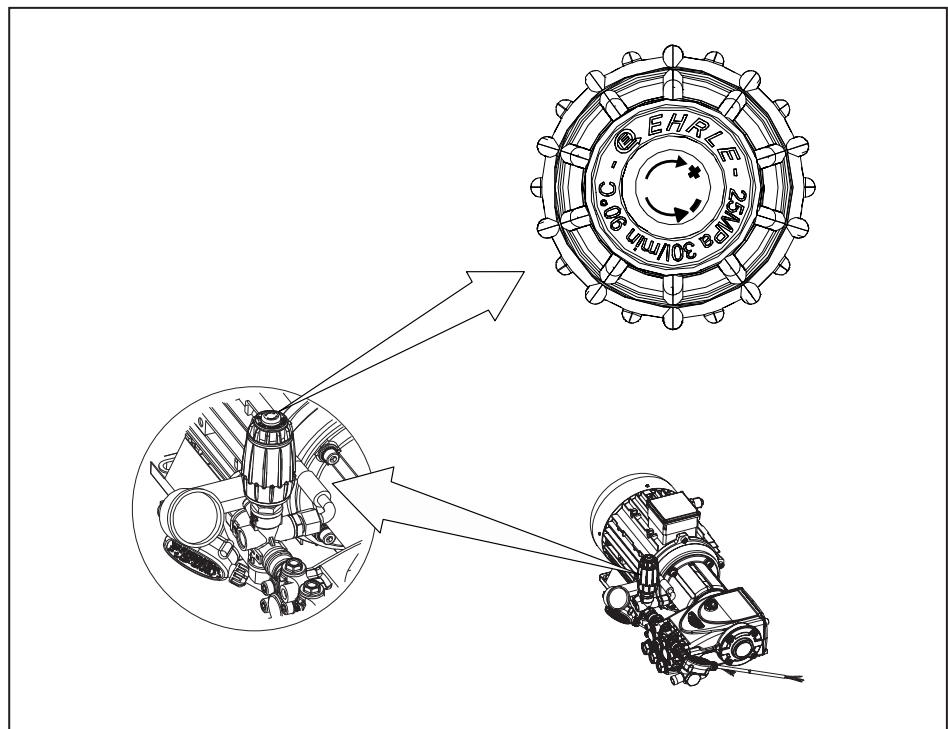

Fig. 6 - 6 Adjustment of the operating pressure at the unloader valve



### General Information

If the system remains in stand-by mode for 20 minutes, the electronic control switches the high pressure cleaner off as programmed.

To resume operation

- ▶ for Series HSC-Electric: set the main switch Start - Stop to position 0 and then back to operating position 1.
- ▶ for Series HSC-Electric FR: press the push-button Start - Stop. The push-button light is on.

- ▶ For adding detergent to the high pressure jet, the detergent control valve inside the cabinet can be set according to the required amount of detergent:
  - for Series HSC-Electric see 4, Fig. 6 - 4
  - for Series HSC-Electric FR see 4, Fig. 6 - 5).The procedure for the addition of detergents is described in section 6.7 (Use of detergents, chemistry).
- ▶ On the front of the cabinet door, the detergent admixture can be switched On/Off
  - for Series HSC-Electric: set the main switch Detergent (3, Abb. 6 - 1) to position 1.
  - for Series HSC-Electric FR: press the push-button Detergent (3, Abb. 6 - 1). The push-button light is on.
- ▶ The cabinet door must be closed during cleaning work.
- ▶ For safety reasons after completion of cleaning work
  - Lock the trigger lever of the trigger gun against unintentional switching on using the locking lever (4, Fig. 6 - 2 for Series HSC-Electric, resp. 3, Fig. 6 - 3 for Series HSC-Electric FR). Ensure that the locking lever is positioned in the notch for the locking lever (6, Fig. 6 - 2 for Series HSC-Electric, resp. 5, Fig. 6 - 3 for Series HSC-Electric FR).
- ▶ On the front of the cabinet door
  - for Series HSC-Electric: set the main switch Start - Stop (1, Fig. 6 - 1) to position 0. The system is switched off.
  - for Series HSC-Electric FR: press the push-button Start - Stop (1, Fig. 6 - 1). The push-button light is off. The system is switched off.

## 6.6 System operation for operating personnel



### General Information

The operation of the system by the operating personnel is limited to switching on/off the three system functions on the control panel on the front of the cabinet door via the three

- ▶ main switches for Series-Electric
- ▶ push-buttons for Series HSC-Electric FR.

For cleaning operation by the operating personnel, proceed as follows:

- ▶ If necessary, open the shut-off valve of the tap water network.



### WARNING

**Before activating, hold the trigger gun and the spray lance tightly.**

After activation of the trigger gun the emerging water jet exerts a jerky recoil force (see also Fig. 6 - 7).

This may result in unintentional jerking away from the selected cleaning object or the trigger gun slipping out of the hand, endangering the life and limb of persons.

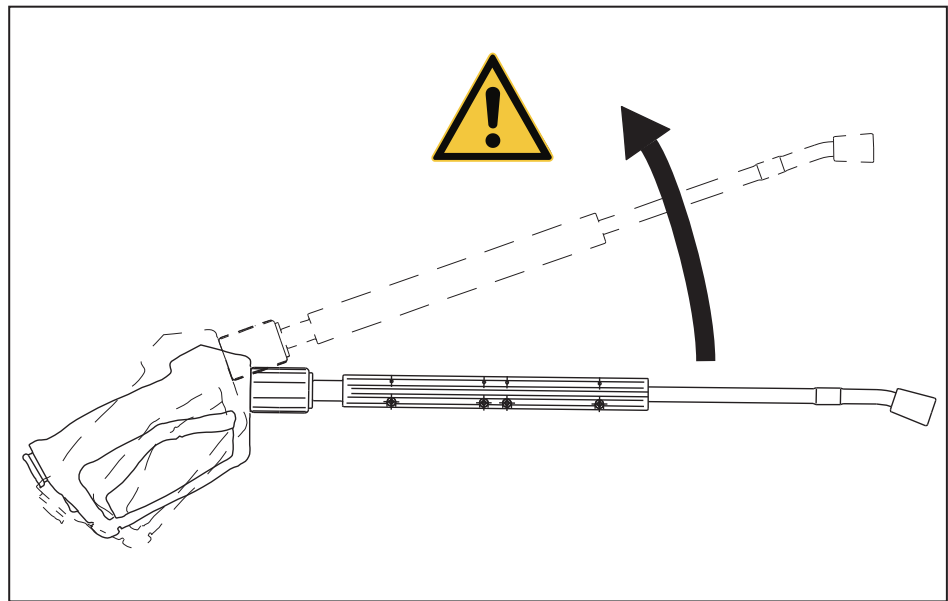

Fig. 6 - 7 Recoil force when switching on the trigger gun

- ▶ Unlock and pull the trigger lever (3, Fig. 6 - 2 for Series HSC-Electric, resp. 2, Fig. 6 - 3 for Series HSC-Electric FR) of the trigger gun.
- ▶ On the front of the cabinet door
  - for Series HSC-Electric: set the main switch Start - Stop (1, Fig. 6 - 1) to position 1.
  - for Series HSC-Electric FR: press the push-button Start - Stop (1, Fig. 6 - 1). The push-button light is on.

The high pressure cleaner starts. The pump first delivers air from the HP-nozzle. After a short time, water then escapes.

- ▶ If the trigger lever on the trigger gun is released, the high pressure cleaner switches to pressureless circulation operation. After 20 sec. circulation mode switches the system to stand-by mode. When the lever on the trigger gun is pulled again, the motor and the pump restart automatically.



#### General Information

If the system remains in stand-by mode for 20 minutes, the electronic control switches the high pressure cleaner off as programmed.

To resume operation

- ▶ for Series HSC-Electric: set the main switch Start - Stop to position 0 and then back to operating position 1.
- ▶ for Series HSC-Electric FR: press the push-button Start - Stop. The push-button light is on.



#### WARNING

##### Risk of scalding due to hot water.

The hot water escaping from the high pressure jet must not come into contact with persons. Otherwise scalding may occur in persons.

- ▶ On the front of the cabinet door, hot water can be switched on at a preset temperature
  - for Series HSC-Electric: set the main switch Hot Water (2, Fig. 6 - 1) to position 1.
  - for Series HSC-Electric FR: press the push-button Hot Water (2, Fig. 6 - 1). The push-button light is on.
- ▶ At the front of the cabinet door, a preset amount of detergent can be switched on for the operating personnel to add to the high pressure jet. For the addition of detergent, proceed in accordance with section 6.7.
- ▶ For safety reasons after completion of cleaning work
  - Lock the trigger lever of the trigger gun against unintentional switching on using the locking lever (4, Fig. 6 - 2 for Series HSC-Electric, resp. 3, Fig. 6 - 3 for Series HSC-Electric FR). Ensure that the locking lever is positioned in the notch for the locking lever (6, Fig. 6 - 2 for Series HSC-Electric, resp. 5, Fig. 6 - 3 for Series HSC-Electric FR).
- ▶ On the front of the cabinet door
  - for Series HSC-Electric: set the main switch Start - Stop (1, Fig. 6 - 1) to position 0. The system is switched off.
  - for Series HSC-Electric FR: press the push-button Start - Stop (1, Fig. 6 - 1). The push-button light is off. The system is switched off.

## 6.7 Use of detergents (chemistry)

For cleaning work with the high pressure cleaner, a cleaning detergent (chemical) can be added to the high pressure jet.

Access for setting the detergent quantity and filling the detergent container in the cabinet is restricted to qualified personnel authorised by the system operator.



### **WARNING**

#### **Only use permitted detergents.**

Only use cleaning detergents approved by the manufacturer EHRLE. The use of inadmissible detergents can endanger the operational safety of the device and thus the life and limb of persons.

There is a risk of poisoning or caustic burns with cleaning detergents. Avoid contact with skin surface and eyes. Observe the manufacturer's safety data sheets. Keep cleaning agents out of the reach of unauthorized persons.

Observe specifications for neutral additive pH value 7 ... 9. Observe the instructions of the additive manufacturer, e.g. Personal Protective Equipment (PPE), waste water regulations.



**WARNING**

**Risk of explosion due to use of inadmissible detergents.**

Never aspirate solvent-containing liquids such as paint thinners, petrol, oil or similar liquids.

The spray of solvents is highly flammable, explosive and toxic.

Observe the specifications of the additive manufacturers!



**CAUTION**

**Observe the safety data sheets for the detergent agents or chemical additives.**

Follow the manufacturer's instructions for detergent agents or chemical additives in the safety data sheets.

Unsuitable and unapproved detergent agents can damage the high pressure cleaner as well as the object to be cleaned.

The temperature specifications for the detergent agents and chemical additives must be observed during hot water operation.

Exceeding temperature limits of the detergent agents or chemical additives during hot water operation can cause damage to the high pressure cleaner.



**CAUTION**

**Chemical dry run or inadmissible detergents can damage the high pressure cleaner.**

Only open the detergent control valve when the suction hose for the detergents in the detergent container is fully inserted and the container is sufficiently filled with detergent.

Intake air causes damage to seals and pumps.

In order to protect the environment, we recommend using detergents sparingly. Observe the dosage recommendations on the container labels of the detergents.

An up-to-date list of approved detergents or chemical additives can be requested from EHRLE.

Observe the safety instructions provided with the cleaning agents used (usually on the packaging label).

For the use of cleaning agents, two detergent containers (each with a capacity of 25 l) can be placed in the space provided inside the cabinet (see Fig. 4 - 3 to Fig. 4 - 6).

Replace an empty detergent container by a new container.

### 6.7.1 Adjust the amount of detergent to be added

The cabinet door must be unlocked and opened with the key by authorised specialist personnel. Proceed as follows to set the amount of detergent to be added:

- ▶ Check the detergent container for filling, replace container with approved detergent if necessary.
- ▶ For adding detergent
  - for Series HSC-Electric: initially, set the detergent control valve (4, Fig. 6 - 4) to position 0.
  - for Series HSC-Electric FR: initially set the detergent control valve (4, Fig. 6 - 5) to position 0.
- ▶ Open the detergent control valve from position „0“ according to the desired quantity of detergent



#### General Information

The more the detergent control valve is opened, the more amount of detergent is sucked in. Depending on the application, set the dosage via the detergent control valve.

### 6.7.2 Adding detergent

For cleaning with detergents proceed as follows:

- ▶ On the front of the cabinet door
  - for Series HSC-Electric: set the main switch Detergent (3, Abb. 6 - 1) to position 1.
  - for Series HSC-Electric FR: press the push-button Detergent (3, Abb. 6 - 1). The push-button light is on.
- ▶ To remove the dirt, spray on the detergent sparingly and let it work for approx. 1 to 5 minutes.
- ▶ Then spray the loosened dirt with the high pressure jet.
- ▶ After using detergents, on the front of the cabinet door
  - for Series HSC-Electric: set the main switch Detergent (3, Abb. 6 - 1) to position 0.
  - for Series HSC-Electric FR: press the push-button Detergent (3, Abb. 6 - 1). The push-button light is off.
- ▶ Rinse the high pressure cleaner for at least 30 seconds.

## 7 Decommissioning

### 7.1 Temporary decommissioning by operating personnel

After completion of cleaning works proceed as follows for a temporary decommissioning:

- ▶ If detergent has been added
  - for Series HSC-Electric: set the main switch Detergent (3, Fig. 6 - 1) to position 0.
  - for Series HSC-Electric FR: press the push-button Detergent (3, Fig. 6 - 1), if the button light is on. The push-button light is off.

Then rinse the high pressure cleaner for at least 30 seconds.

- ▶ After hot water operation
  - for Series HSC-Electric: set the main switch Hot Water (2, Fig. 6 - 1) to position 0.
  - for Series HSC-Electric FR: press the push-button Hot Water (2, Fig. 6 - 1), if the button light is on. The push-button light is off.

The high pressure cleaner must be operated with cold water for at least two minutes with the trigger gun open for cooling.

- ▶ Pull the lever of the trigger gun until the high pressure cleaner is depressurized.



#### WARNING

##### Lock the lever of the trigger gun after completion of cleaning work.

After deactivating the trigger gun, lock the trigger lever (3, Fig. 6 - 2 for Series HSC-Electric, resp. 2, Fig. 6 - 3 for Series HSC-Electric FR) against unintentional switching on by means of the locking lever (4, Fig. 6 - 2 for Series HSC-Electric, resp. 3, Fig. 6 - 3 for Series HSC-Electric FR). Ensure that the locking lever is correctly positioned in the notch for the locking lever (6, Fig. 6 - 2 for Series HSC-Electric, resp. 5, Fig. 6 - 3 for Series HSC-Electric FR).

Unintentional activation of the trigger gun after restarting the device can endanger life and limb of persons.

- ▶ Lock the trigger lever (3, Fig. 6 - 2 for Series HSC-Electric, resp. 2, Fig. 6 - 3 for Series HSC-Electric FR) of the trigger gun against unintentional switching on using the locking lever (4, Fig. 6 - 2 for Series HSC-Electric, resp. 3, Fig. 6 - 3 for Series HSC-Electric FR). Ensure that the locking lever is arrested in the notch for locking lever (6, Fig. 6 - 2 for Series HSC-Electric, resp. 5, Fig. 6 - 3 for Series HSC-Electric FR).
- ▶ On the front of the cabinet door
  - for Series HSC-Electric: set the main switch Start - Stop (1, Fig. 6 - 1) to position 0. The system is switched off.
  - for Series HSC-Electric FR: press the push-button Start - Stop (1, Fig. 6 - 1), if the button light is on. The push-button light is off. The system is switched off.
- ▶ If necessary, close the shut-off valve on the building side of the tap water network.

- ▶ If necessary, switch off the power supply via the circuit breaker resp. main switch on the building side.
- ▶ If necessary, disconnect the mains cable of the system from the mains connection of the building.

## 7.2 Temporary decommissioning by qualified personnel

After completion of cleaning works proceed as follows for a temporary decommissioning:

- ▶ If detergent has been added
  - for Series HSC-Electric: set the main switch Detergent (3, Fig. 6 - 1) to position 0.
  - for Series HSC-Electric FR: press the push-button Detergent (3, Fig. 6 - 1), if the button light is on. The push-button light is off.

Then rinse the high pressure cleaner for at least 30 seconds.

- ▶ After hot water operation
  - for Series HSC-Electric: set the main switch Hot Water (2, Fig. 6 - 1) to position 0.
  - for Series HSC-Electric FR: press the push-button Hot Water (2, Fig. 6 - 1), if the button light is on. The push-button light is off.

The high pressure cleaner must be operated with cold water for at least two minutes with the trigger gun open for cooling.

- ▶ Pull the lever of the trigger gun until the high pressure cleaner is depressurized.



### WARNING

#### Lock the lever of the trigger gun after completion of cleaning work.

After deactivating the trigger gun, lock the trigger lever (3, Fig. 6 - 2 for Series HSC-Electric, resp. 2, Fig. 6 - 3 for Series HSC-Electric FR) against unintentional switching on by means of the locking lever (4, Fig. 6 - 2 for Series HSC-Electric, resp. 3, Fig. 6 - 3 for Series HSC-Electric FR). Ensure that the locking lever is correctly positioned in the notch for the locking lever (6, Fig. 6 - 2 for Series HSC-Electric, resp. 5, Fig. 6 - 3 for Series HSC-Electric FR).

Unintentional activation of the trigger gun after restarting the device can endanger life and limb of persons.

- ▶ Lock the trigger lever (3, Fig. 6 - 2 for Series HSC-Electric, resp. 2, Fig. 6 - 3 for Series HSC-Electric FR) of the trigger gun against unintentional switching on using the locking lever (4, Fig. 6 - 2 for Series HSC-Electric, resp. 3, Fig. 6 - 3 for Series HSC-Electric FR). Ensure that the locking lever is arrested in the notch for locking lever (6, Fig. 6 - 2 for Series HSC-Electric, resp. 5, Fig. 6 - 3 for Series HSC-Electric FR).
- ▶ On the front of the cabinet door
  - for Series HSC-Electric: set the main switch Start - Stop (1, Fig. 6 - 1) to position 0. The system is switched off.
  - for Series HSC-Electric FR: press the push-button Start - Stop (1, Fig. 6 - 1), if the button light is on. The push-button light is off. The system is switched off.

- ▶ If necessary, unlock and open the cabinet door with the key.
- ▶ If necessary, move the following control elements inside the cabinet to switch-off position 0:
  - Thermostat (5, Fig. 6 - 4 for Series HSC-Electric, resp. 5, Fig. 6 - 5 for Series HSC-Electric FR).
  - Detergent control valve (4, Fig. 6 - 4 for Series HSC-Electric, resp. 4, Fig. 6 - 5 for Series HSC-Electric FR).
- ▶ If necessary, leave the unloader valve (3, Fig. 6 - 4 for Series HSC-Electric, resp. 3, Fig. 6 - 5 for Series HSC-Electric FR) as it is.
- ▶ If necessary, close the shut-off valve on the building side of the tap water network.
- ▶ For decommissioning the system for a longer period of time, switch off the power supply to the system via the circuit breaker of the mains connection on the building side.
- ▶ If necessary, disconnect the power supply cable of the system from the mains connection of the building.

### **7.3 Decommissioning for a longer period of time**

If the high pressure cleaner is to be taken out of operation for a longer period of time, refer to Section 7.1 resp. 7.2 and take it out of operation temporary.

After dismantling for storage over a longer period of time, place the system and all accessories (trigger gun, spray lance, HP-hose, etc.) in a frost-protected storage location. Otherwise, provide frost protection (refer also to Section 8.3.1 (Frost Protection)).

## 8 Maintenance



### **WARNING**

#### **Carry out maintenance measures professionally.**

Maintenance of the system may only be carried out by qualified, trained and authorised personnel.

Before carrying out any maintenance work, take the system out of operation and disconnect it from the building's electrical supply.

### 8.1 General Information

The maintenance measures must be carried out professionally as well as regularly and mean for the system:

- Guarantee of operational safety.
- Achieving a long service life.
- Maintaining the performance.

### 8.2 EHRLE Maintenance and Inspection Contract

The company EHRLE offers with the sale of the system a maintenance contract or especially a safety inspection agreement. The maintenance contract includes:

- Maintenance and repair work
- Security inspection agreement.

The security inspection agreement includes the inspection according to:

- Guidelines for Liquid Sprayers (see section 2.10).

### 8.3 Maintenance work

Components which show increased wear or whose design duration has been exceeded or is exceeded before the next maintenance must be replaced as a precaution.

The following table contains the periodical maintenance work for the Stationary Hotwater High Pressure Cleaners of Series HSC-Electric and Series HSC-Electric FR.

<b>Period</b>	<b>Component</b>	<b>Measure</b>	<b>Authorized personnel</b>
Daily	Trigger gun	Check if trigger gun closes tightly; check function of mechanical locking to prevent unintentional switch-on; replace defective trigger gun.	Trained operator
	All HP-Hoses (inside /outside cabinet)	Check the HP-Hoses (see section 8.3.4).	Skilled worker (with access to cabinet interior)
	Electrical plug and cables (inside / outside cabinet)	Check plugs and cables for damage. Replace damaged plugs and/or cables immediately by an authorized customer service/electrical specialist.	Customer Service/ Electrical Specialist
Weekly or after 40 operating hours.	Check the oil condition in the oil tank at the pump.	With poor oil quality (milky etc.), change the oil according to section 8.3.3.	Skilled worker (with access to cabinet interior)
	Check the oil level in the oil tank on the pump.	Check pump oil level, top up oil if necessary (see section 8.3.3).	Skilled worker (with access to cabinet interior)
	Water inlet filter	Check filter for dirt and clean if necessary, see section 8.3.2.	Trained operator
	Filter from detergent hose	Check filter for dirt and clean if necessary.	Skilled worker (with access to cabinet interior)
	Detergent container	Check detergent container for sufficient filling. If necessary, replace container by new detergent container.	Skilled worker (with access to cabinet interior)
Monthly or after 200 operating hours	High pressure pump	Check pump for leakage. If more than three drops per minute call customer service.	Skilled worker (with access to cabinet interior) resp. Customer Service
Every six months or if required	Check all piping in the entire system for internal deposits.	Operate system with spray lance without HP-nozzle. If the operating pressure at the pressure gauge exceeds 3 MPa, the system must be descaled. The same applies if an operating pressure of more than 0.7-1 MPa is detected during operation without a high pressure line (water exits freely at the high pressure outlet).	Skilled worker (with access to cabinet interior) trained on descaling procedure.
	HP-nozzle	Replace HP-nozzle.	Trained operator

Tab. 8 - 1 List of periodical maintenance work

Period	Component	Measure	Authorized personnel
Every six months or after 1000 operating hours	High pressure pump	Change the oil according to section 8.3.3.	Skilled worker (with access to cabinet interior)
	Check the entire system for dirt, damage and function	Visual inspection of the system, check high pressure connections for leaks, check overflow valve for leaks, check high pressure hoses, check pressure tank etc.	Customer Service
Annually	Safety check for the entire system.	Carry out a safety check in accordance with the respective national regulations of the legislator for liquid sprayers.	Qualified expert

Tab. 8 - 1 List of periodical maintenance work

### 8.3.1 Frost protection



#### General Information

For locations of Stationary Hotwater High Pressure Cleaners with environmental conditions below freezing point, EHRLE offers detailed advice.

The Series HSC-Electric FR are units with frost protection and allow operation in locations with ambient conditions at temperatures up to -20 °C.

For optimum protection, store the high pressure cleaner in a frost-protected area.

If the systems are exposed to temperatures below freezing point during decommissioning for a longer period of time (e.g. temporary storage in a warehouse), frost protection must be provided.

### 8.3.2 Cleaning the filter in water inlet

#### 8.3.2.1 HSC-Electric

To clean the filter proceed as follows:

- ▶ Close water inlet.
- ▶ Unscrew the water inlet hose from the unit.
- ▶ Use a screwdriver to push the filter out of the connection.
- ▶ Clean filter, resp. replace damaged filter.
- ▶ Reassemble in reverse order.

### 8.3.2.2 HSC-Electric FR

To clean the filter proceed as follows:

- ▶ Close water inlet (ball valve).
- ▶ Loosen the union nut on the filter and remove it from the filter cup together with the sight glass.
- ▶ Clean filter, resp. replace damaged filter.
- ▶ Reassemble in reverse order.

### 8.3.3 Oil change

Use the following type of oil to change the oil in the gear unit of the high pressure pump:

- Engine oil SAE 10W40.

To change the oil in the gearbox of the high pressure pump, proceed as follows:

- ▶ Remove the oil dipstick.
- ▶ Extract the oil (observe environmental protection when handling waste oil).
- ▶ Fill oil up to the „MAX“ mark on the oil dipstick.

### 8.3.4 Checking the HP-Hoses



#### **WARNING**

**Operation with worn, damaged or repaired HP-Hoses can endanger life and limb of persons.**

Ensure that HP-Hoses are removed immediately in the case of:

- Signs of wear.
- Signs indicating repairs to the HP-Hose.
- Overaging and low durability.

Bursting or leaky HP-Hoses can cause hot high pressure water or steam to escape. This can endanger life and limb of persons.

Before each commissioning of the high pressure cleaners, carry out a visual inspection of the HP-Hoses for damage. Every HP-Hose must comply with the safety regulations and be marked with:

- Permissible operating pressure.
- Permissible operating temperature.
- Date of manufacture.
- Manufacturer.

Replace the HP-Hose at the slightest sign of damage.

Only use spare parts recommended by the manufacturer (see spare parts catalogue).

## 9 Troubleshooting



**WARNING**

**Carry out troubleshooting and rectification properly.**

Troubleshooting of the system may only be carried out by qualified, trained and authorised personnel.

Before troubleshooting inside the cabinet, take the system out of operation and disconnect the mains connection cable from the mains connection of the building.

### 9.1 Troubleshooting table

For troubleshooting purposes, possible error causes are listed in the following table.

Clean the contaminated parts (filter, HP-nozzle, etc.) to eliminate possible faults. Replace defective parts.

Error	Possible cause	Remedying	Authorised personnel
System cannot be switched on	Check that the power supply cable is plugged in.	Connect the power supply cable to the building power supply.	Trained operator
	Building supply circuit breaker has tripped.	Switch the circuit breaker on again.	Trained operator
	Check if power supply cable is defective.	Replace defective power supply cable.	Customer Service/ Electrical Specialist
	Circuit breaker trips again after repeated switching on.	If building power supply is OK, system defective; disconnect power supply cable and contact customer service.	Customer Service
	Water level in the electric heated boiler at the float valve inlet too low.	Locate the cause of the low water level (water inlet blocked, too low or too low due to contamination, dirty filter in the water inlet, dirty filter etc.).	Skilled worker (with access to cabinet interior).

Tab. 9 - 1 Troubleshooting table

<b>Error</b>	<b>Possible cause</b>	<b>Remedying</b>	<b>Authorised personnel</b>
System cannot be switched on (continued)	Motor of high pressure cleaner overheated.	Allow motor to cool down, with Series HSC-Electric: set the main switch Start - Stop (1, Fig. 6 - 1) to position 0. with Series HSC-Electric FR the push-button light of Start - Stop (1, Fig. 6 - 1) is off. After motor cooling: with Series HSC-Electric: set the main switch Start - Stop to position 1. with Series HSC-Electric FR; press the push-button Start - Stop, the push-button light is on.	Skilled worker (with access to cabinet interior).
	With series HSC-Electric fuse F2 defective. With series HSC-Electric FR fuse F4 defective.	Switch off the power supply to the system and disconnect the power supply cable from the mains supply.  Unscrew the protective cover from the electrical control box and check the respective fuse.	Skilled worker (with access to cabinet interior).
	System control circuits or components defective.	Replace defective components.	Customer Service
System has switched off in stand-by mode.	System was in stand-by mode for 20 minutes. Electronic control has switched off high pressure cleaner according to program.	To resume operation, with Series HSC-Electric: set the main switch Start - Stop (1, Fig. 6 - 1) to position 0 and then back to operation position 1. with Series HSC-Electric FR press the push-button Start - Stop (1, Fig. 6 - 1), the push-button light is on.	Trained operator
No pressure build-up with high pressure cleaners	HP-nozzle dirty or defective.	Clean or replace HP-nozzle..	Trained operator
	Filter in water inlet dirty.	Clean the filter, see section 8.3.2.	Trained operator
	Water inflow volume is too low.	Ensure sufficient water inflow volume.	Skilled worker (with access to cabinet interior).
	One or more supply lines of the pump are clogged.	Remove the blockage in the supply line.	Skilled worker (with access to cabinet interior).

Tab. 9 - 1 Troubleshooting table

<b>Error</b>	<b>Possible cause</b>	<b>Remedying</b>	<b>Authorised personnel</b>
No pressure build-up with high pressure cleaners	Water inflow volume is too low.	Ensure sufficient water inflow volume.	Skilled worker (with access to cabinet interior).
	One or more supply lines of the pump are clogged.	Remove the blockage in the supply line.	Skilled worker (with access to cabinet interior).
	One or more supply lines of the pump are leaking.	Replace leaking supply lines.	Customer Service
	Detergent control valve is leaking.	Replace leaking detergent control valve.	Customer Service
	Unloader valve is contaminated.	Clean the unloader valve.	Customer Service
	Unloader valve is defective.	Replace defective unloader valve.	Customer Service
	High pressure pump valves are dirty or defective.	Clean or replace valves.	Customer Service
	Cuffs of the high pressure pump are dirty or defective.	Clean or replace cuffs.	Customer Service
No or insufficient water-heating, Series HSC-Electric: main switch Start - Stop is in position 1, Series HSC-Electric FR: push-button light Start - Stop is on.	Thermostat is in „Off“ position (5, Fig. 6 - 4 for Series HSC-Electric or 5, Fig. 6-5 for Series HSC-Electric FR).	Set the Thermostat to the desired temperature.	Skilled worker (with access to cabinet interior).
	HSC-Electric: main switch in position 0; resp. HSC-Electric FR: push-button Hot Water is not on.	HSC-Electric: set main switch to position 1; resp. HSC-Electric FR: press push-button Hot Water, the push-button light is on.	Skilled worker (with access to cabinet interior).
	One or more circuit breakers for the heating elements have tripped.	Switch the circuit breaker back on (electrical control box).	Customer Service
		If the circuit breakers trip again after being switched on again, there is a fault in the system; take the system out of operation.	Customer Service

Tab. 9 - 1 Troubleshooting table

<b>Error</b>	<b>Possible cause</b>	<b>Remedying</b>	<b>Authorised personnel</b>
(continued)	Heating elements are calcified.	Switch off the power supply to the system and disconnect the power supply cable from the mains supply.	Customer Service
	One or more heating elements are defective.	Switch off the power supply to the system and disconnect the power supply cable from the mains supply.	Customer Service
	Operating pressure below 25 bar.	Check causes for operating pressure below 25 bar.	Skilled worker (with access to cabinet interior).
	System components or system control circuits defective (pressure switch, flow monitor, ETRONIC control unit, etc.).	Replace defective components.	Customer Service
No or insufficient detergent admixture, Series HSC-Electric: main switch Start - Stop is in position 1, Series HSC-Electric FR: Push-button light Start - Stop (1, Fig. 6-1) is on.	HSC-Electric: main switch Detergent in position „0“ resp. HSC-Electric FR: push-button light Detergent is off.	HSC-Electric: set main switch Detergent in position „1“ resp. HSC-Electric FR: press push-button Detergent, the push-button light is on.	Skilled worker (with access to cabinet interior).
	Detergent container is empty.	If necessary, provide new detergent container.	Skilled worker (with access to cabinet interior).
	Detergent control valve is in position 0 (4, Fig. 6 - 4 for Series HSC-Electric, resp. 4, Fig. 6-5 for Series HSC-Electric FR).	Open detergent control valve to the desired quantity of detergent.	Skilled worker (with access to cabinet interior).
	Filter from detergent hose or detergent hose contaminated or clogged.	Clean filter or detergent hose or remove blockages.	Skilled worker (with access to cabinet interior).
	Modules of the detergent admixture defective.	Replace defective modules.	Customer Service

Tab. 9 - 1 Troubleshooting table

## **9.2 Replacement of components and parts**

Replace the defective components and parts.

Only use spare parts recommended and approved by the manufacturer.



## 10 Circuit diagrams

### 10.1 HSC840-INOX 24kW

0123456789





**www.ehrle.com**

*The better way to clean*

F26\_001

Projektbeschreibung Zeichnungsnummer	HSC 823 ab 05.2023
Hersteller (Firma)	Ehrle GmbH Siemensstraße 9 89257 Illertissen
Projektname Fabrikat Typ	HSC 823 ab 05.2023
Erstellt am Bearbeitet am	16.06.2023 Anzahl der Seiten: 5

Datum	16.01.2007
Gepr. Urspr.	HSC 823 ab 05.2023
Name	FRANK/Schiffelsteinwerk(G) 2016

Inventar-Nr.	
Erstellt durch	

Ehrle GmbH	Titelblatt

Fig. 10 - 1 HSC840-INOX 24kW, Circuit diagram (Page 1 of 4)

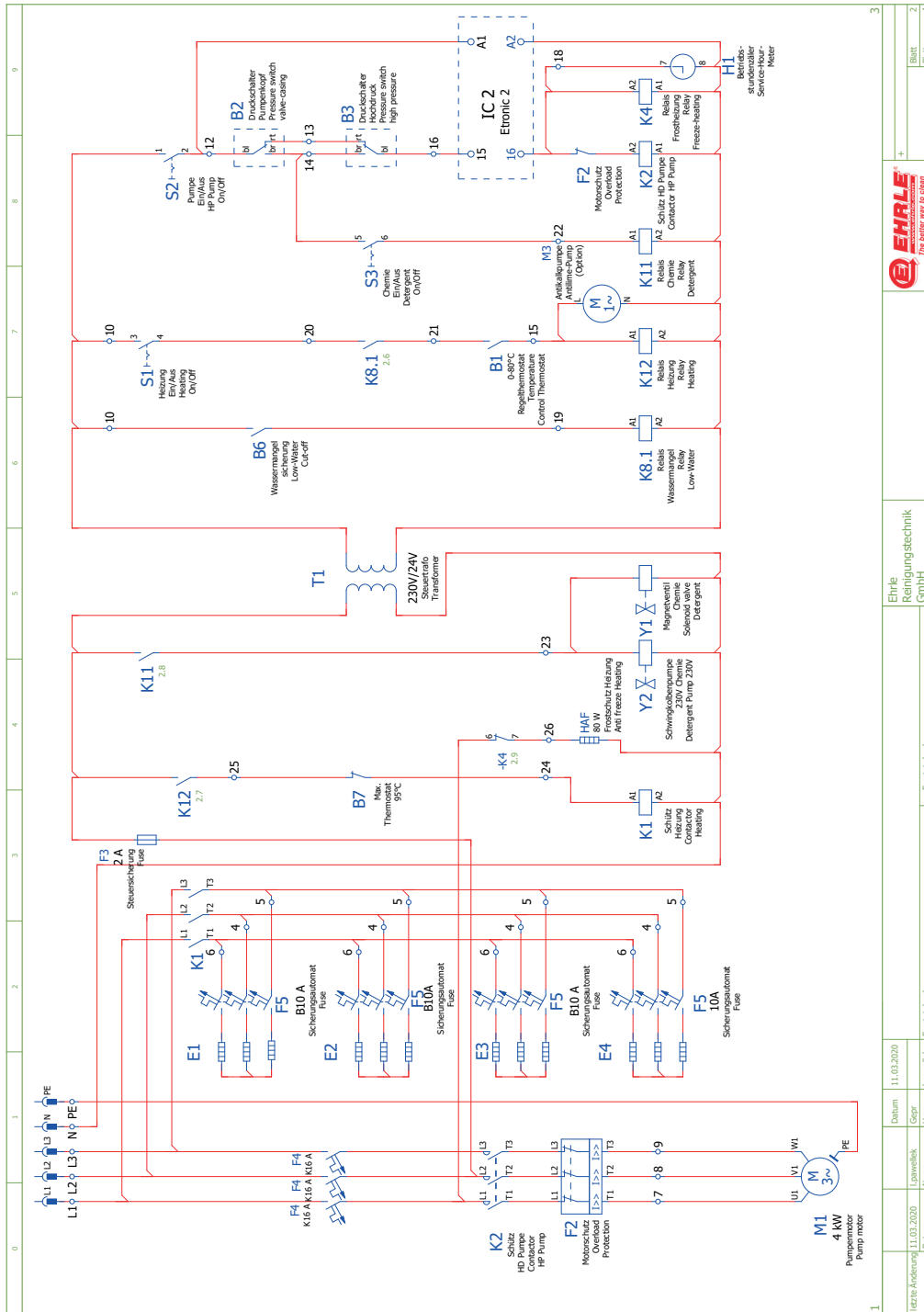

Fig. 10 - 2 HSC840-INOX 24kW, Circuit diagram (Page 2 of 4)

Artikelstückliste									
0	1	2	3	4	5	6	7	8	9
Benennung (BWK) Schaltplan / Position	Menge	Bezeichnung	Typnummer Bestellnummer	Hersteller Lieferant	Artikelnummer Funktionsart	Pos	F01_004		
B1 2.7	1	Kontaktthermom. 0-120 °C Temperature control thermostat 0-120°			2249				
B2 2.8	1	Druckschalter 1/4 " 25 bar 3,0m Pressure switch 1/4 " 25 bar 3,0m			1263202				
B3 2.8	1	Druckschalter 1/4 " 25 bar 3,0m Pressure switch 1/4 " 25 bar 3,0m			1263202				
B6 2.6	1	Wassermangel 4,5m Low-water cut-off 4,5m			27481				
B7 2.4	1	Maximum Thermostat 95 °C Maximum Thermostat 95 °C			24372				
E1 2.2	1	Heizstab 6 kW Heating-Rod 6kW			2140				
E2 2.2	1	Heizstab 6 kW Heating-Rod 6kW			2140				
E3 2.2	1	Heizstab 6 kW Heating-Rod 6kW			2140				
E4 2.2	1	Heizstab 6 kW Heating-Rod 6kW			2140				
F2 2.0	1	Überlastschutz 10,5A 3-pol. Overload Protection 3-ph 10,5A			214507				
F3 2.3	1	Klemme ZSI 2,5 Terminal ZSI 2,5			38331				
F3 2.3	1	Schmelzsicherung 2A Fuse 2A			3723				
F4 2.0	4	Sicherungsautomat K 16 A Automatic circuit K 16 A			54181				
F5 2.2	15	Sicherungsautomat B 10 A Automatic circuit B10 A			5154				
H1 2.9	1	Betriebsstundenzähler 24 V Service-hour-meter 24V			275201				
HAF 2.4	1	Heizung Anti-Frost 230VAC/80W Heating Anti-Freeze 230VAC/80W			283707				
IC2 2.8	1	Elektronische Steuerung 2 T neu Electronic control 2 T			35092				
K1 2.3	1	Schütz LC1 D50 P7 230V Contactor LC1 D50 P7 230V			22051				
K2 2.8	1	Kilbo 7,5kW Schutz 24 V Kilbo 7,5kW Contactor 24V			23162				

Fig. 10 - 3 HSC840-INOX 24kW, Circuit diagram (Page 3 of 4)





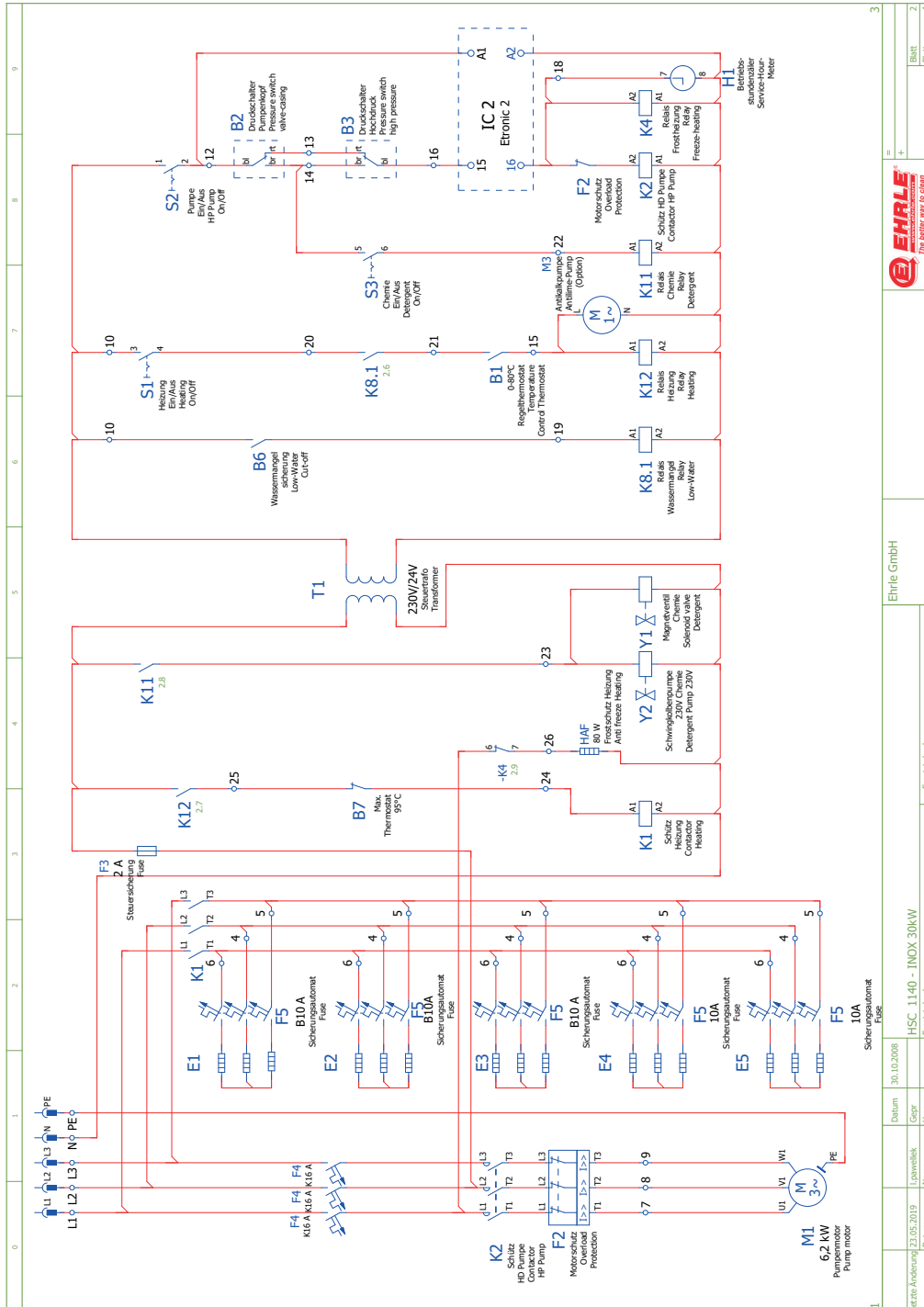

Fig. 10 - 6 HSC1140-INOX 30 kW, Circuit diagram (Page 2 of 4)

Artikelstückliste									
0	1	2	3	4	5	6	7	8	9
Benennung (BWK) Schaltplan / Position	Menge	Bezeichnung	Typnummer Bestellnummer	Hersteller Lieferant	Artikelnummer Funktionsart	Pos	F01_004		
B1 2.7	1	Kontaktfermentherm. 0-120 °C Temperature control thermostat 0-120°			2249				
B2 2.8	1	Druckschalter 1/4 " 25 bar 3,0m Pressure switch 1/4 " 25 bar 3,0m			1263202				
B3 2.8	1	Druckschalter 1/4 " 25 bar 3,0m Pressure switch 1/4 " 25 bar 3,0m			1263202				
B6 2.6	1	Wassermangelsicherung 4,5m Low water Cut Off 4,5m			27481				
B7 2.4	1	Maximum Thermostat 95 °C Maximum Thermostat 95 °C			24372				
E1 2.1	1	Heizstab 6 kW Heating-Rod 6kW			2140				
E2 2.1	1	Heizstab 6 kW Heating-Rod 6kW			2140				
E3 2.1	1	Heizstab 6 kW Heating-Rod 6kW			2140				
E4 2.1	1	Heizstab 6 kW Heating-Rod 6kW			2140				
E5 2.1	1	Heizstab 6 kW Heating-Rod 6kW			2140				
F2 2.0	1	Überlastschutz 3 - pol. 15,5 A Overload Protection 3 ph 15,5A			214512				
F3 2.3	1	Klemme ZSI 2,5 Terminal ZSI 2,5			38331				
F3 2.3	1	Schmelzsicherung 2A Fuse 2A			3723				
F4 2.0	4	Sicherungsautomat K 16 A Automatic circuit K 16 A			54181				
F5 2.2	15	Sicherungsautomat B 10 A Fuse B10 A			5154				
H1 2.9	1	Betriebsstundenzähler 24 V Service-hour-meter 24V			275201				
HAF 2.4	1	Heizung Anti-Frost 230VAC/80W Heating Anti-Freeze 230VAC/80W			283707				
IC2 2.8	1	Elektron. Steuerung 2 T neu Electronic control 2 T			35092				
K1 2.3	1	Schütz LC1 D50 P7 230V Contactor LC1 D50 P7 230V			22051				

2	3.a
Werkzue-Aenderung 23.05.2019 Datum	23.05.2019 Datum
Laywskk Name	Ehrle GmbH
Gepr. Uspr.	HSC 1140 - INOX 30kW
	Ersetzt durch
	Artikelstückliste : 2249 - 22051
	The better way to clean
	Blatt 3
	Blatt 4

Fig. 10 - 7 HSC1140-INOX 30 kW, Circuit diagram (Page 3 of 4)

Artikelstückliste									
0	1	2	3	4	5	6	7	8	9
Benennung (BMK) Schaltplan / Position	Menge	Bezeichnung	Typnummer Bestellnummer	Hersteller Lieferant	Artikelnummer Funktionscode	Pos			
K2 2.8	1	Kilbo 7,5kW Schutz 24 V			23162				
K4 2.9	1	Kilbo 7,5kW Contactor 24V			23162				
K8.1 2.6	1	Kilbo 7,5kW Contactor 24V			50565				
K11 2.8	1	Koppelrelais mit Fass: 24V 8A Relay with socket 24V 8A			50565				
K12 2.7	1	Koppelrelais mit Fass: 24V 8A Relay with socket 24V 8A			50565				
M1 2.0	1	Motor 3 ph 6,2kW			355601				
S1 2.7	1	Schalter B2N-F35-B-RG9 (0-1, HSC-ST) Switch B2N-F35-B-RG9 (0-1, HSC-ST)			204602				
S2 2.8	1	Schalter B2N-F35-B-RG9 (0-1, HSC-ST) Switch B2N-F35-B-RG9 (0-1, HSC-ST)			204602				
S3 2.5	1	Schalter B2N-F35-B-RG9 (0-1, HSC-ST) Switch B2N-F35-B-RG9 (0-1, HSC-ST)			204602				
T1 2.5	1	Transformator 230/24V 30 VA Transformer 230/24V 30 VA			232001				
Y1 2.5	1	MV DIN4 HSC-ST Chemie 230V D223 Solenoid valve DIN4 230V D223 HST-ST Detergent			5373				
Y2 2.4	1	Schwingkolben-Pumpe 508 Detergent Pump			593500				

3									
Werte:	Änderung	23.05.2019	Datum	23.05.2019	HSC 1140 - INOX 30kW				
	Urspr.	EPN/AN Schweißarbeiten (0 2619)	Ersetzt durch						
					Ehrle GmbH	Artikelstückliste : 23162 - 593500			
							Blatt	3	3

Fig. 10 - 8 HSC1140-INOX 30 kW, Circuit diagram (Page 4 of 4)

### 10.3 HSC840-INOX FR 24 kW

0123456789

F26\_001



# EHRLE®

[www.ehrle.com](http://www.ehrle.com)

*The better way to clean*

Projektbeschreibung Zeichnungsnummer	HSC 840 INOX ELEKTRISCH BEHEIZT MIT FROSTSCHUTZ ab 2023 HSC 840 INOX ELECTRIC HEATED WITH ANTIFREEZE CIRCULATION from 2023
Hersteller (Firma)	Ehrle GmbH Industriestraße 3 89165 Dietenheim
Projektname Fabrikat Typ	HSC 840 INOX ELEKTRISCH BEHEIZT MIT FROSTSCHUTZ ab 2023 HSC 840 INOX ELECTRIC HEATED WITH ANTIFREEZE from 2023
Erstellt am Bereitet am	13.10.2023 13.10.2023 Anzahl der Seiten

---

Datum	13.10.2023	HSC 840 INOX ELECTRIC HEATED WITH ANTIFREEZE CIRCULATION from 2023	Titelblatt / Title Page	2
Werte Änderung	13.10.2023	HSC 840 INOX ELEKTRISCH BEHEIZT MIT FROSTSCHUTZ ab 2023	Ehrle Reinigungstechnik GmbH	
Uspz.	Uspz.	Erstellt durch		
Name	Uspz.			

Fig. 10 - 9 HSC840-INOX FR 24 kW, Circuit diagram (Page 1 of 12)







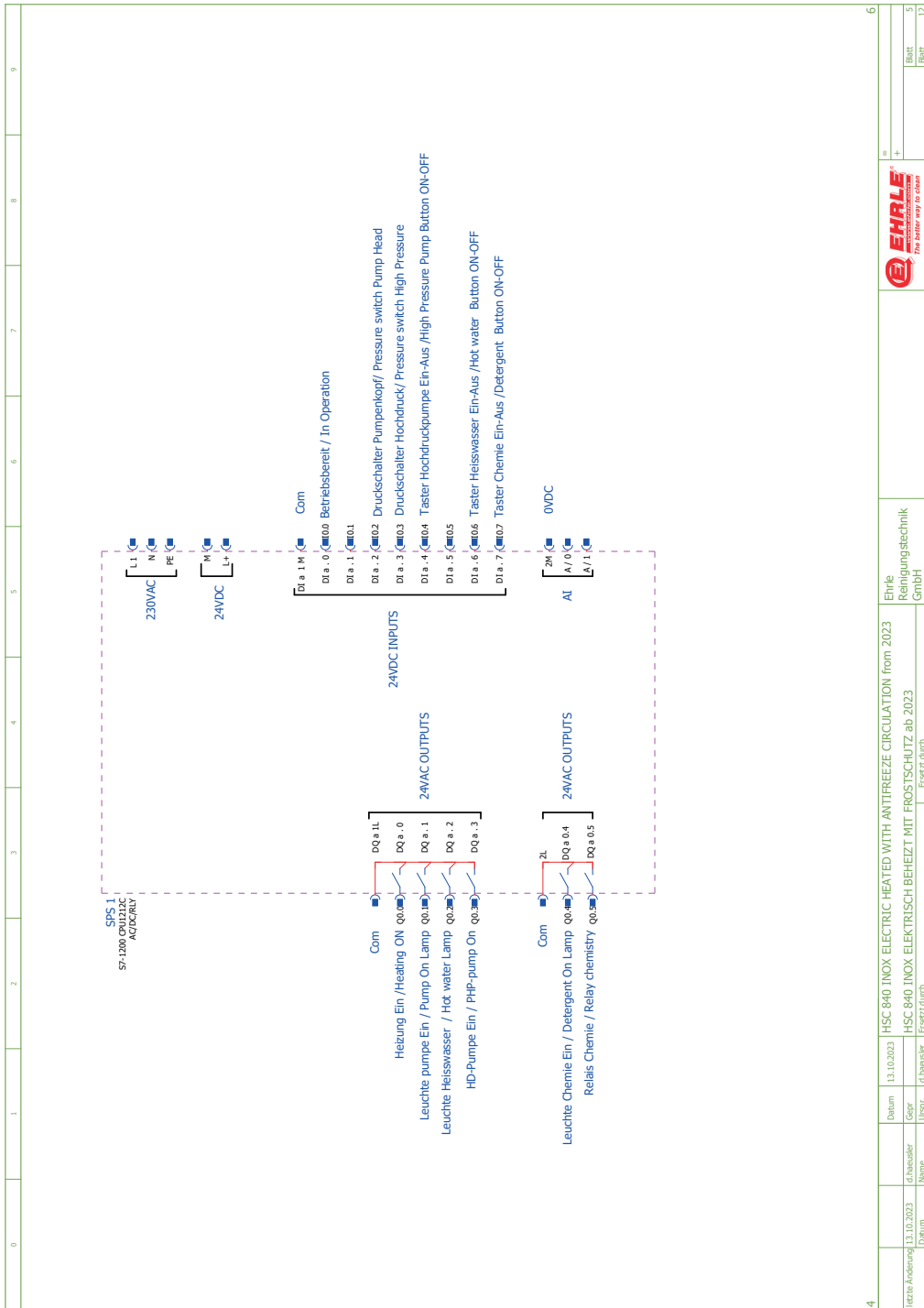

Fig. 10 - 13 HSC840-INOX FR 24 kW, Circuit diagram (Page 5 of 12)





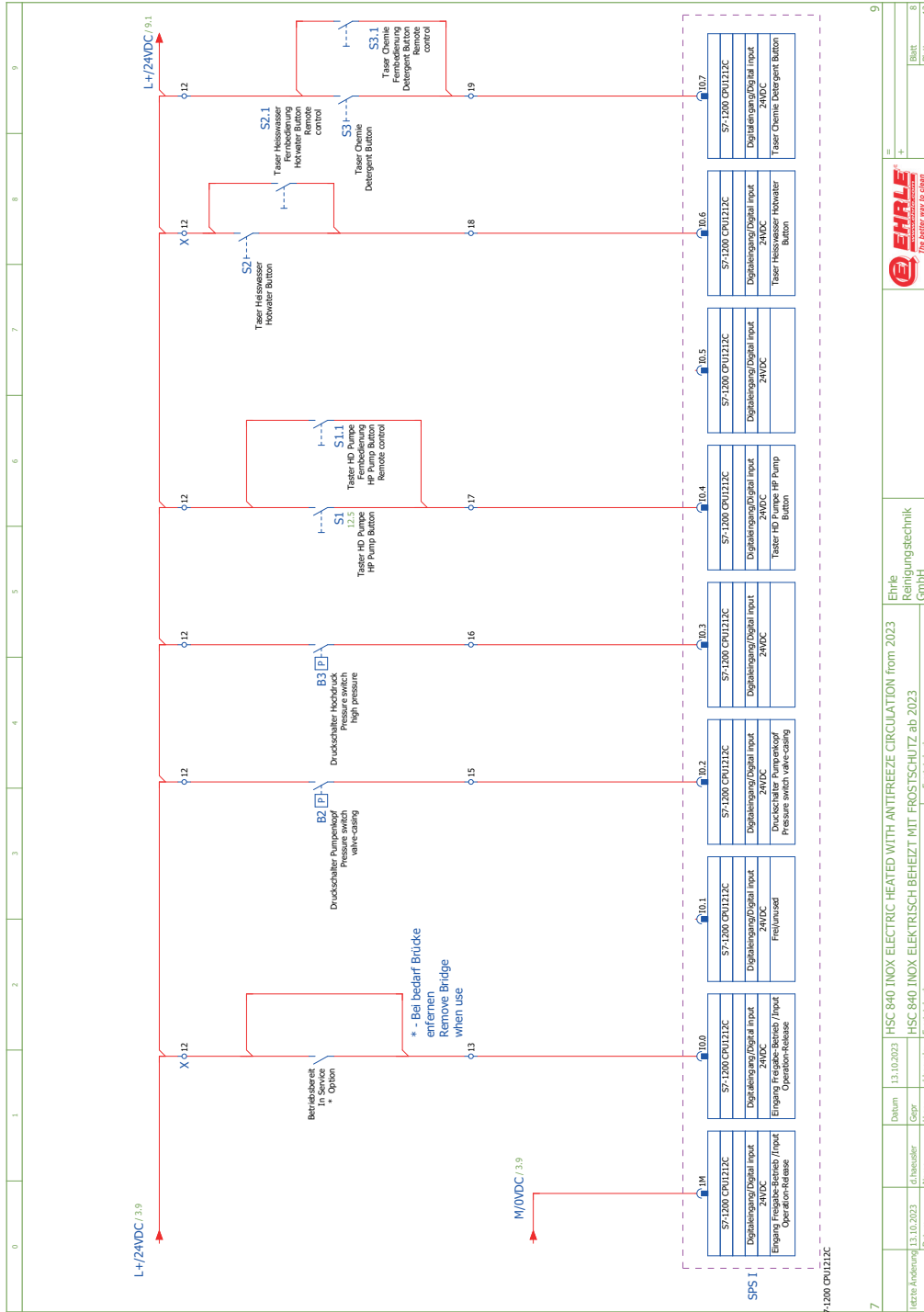

Fig. 10 - 16 HSC840-INOX FR 24 kW, Circuit diagram (Page 8 of 12)

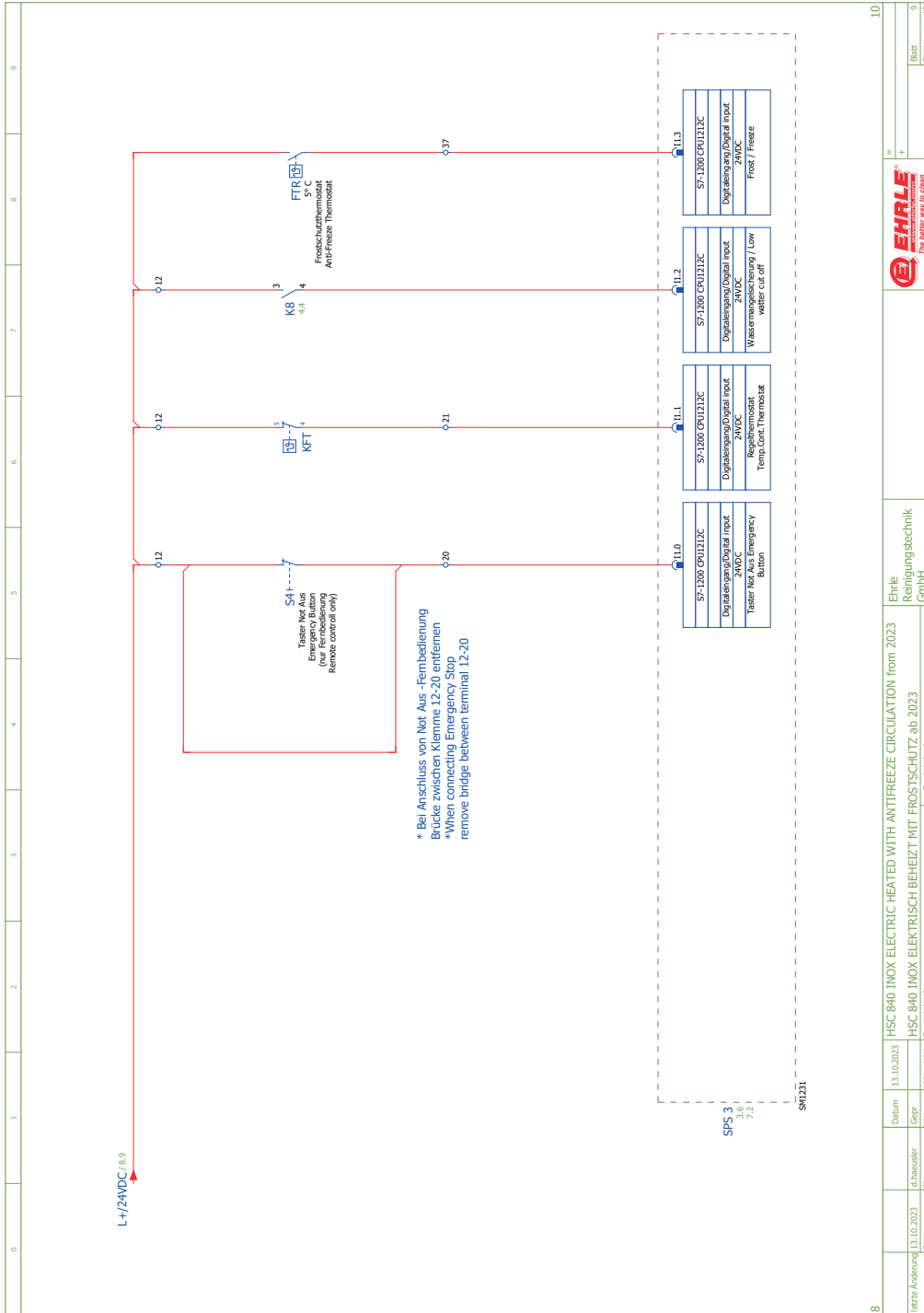

Fig. 10 - 17 HSC840-INOX FR 24 kW, Circuit diagram (Page 9 of 12)

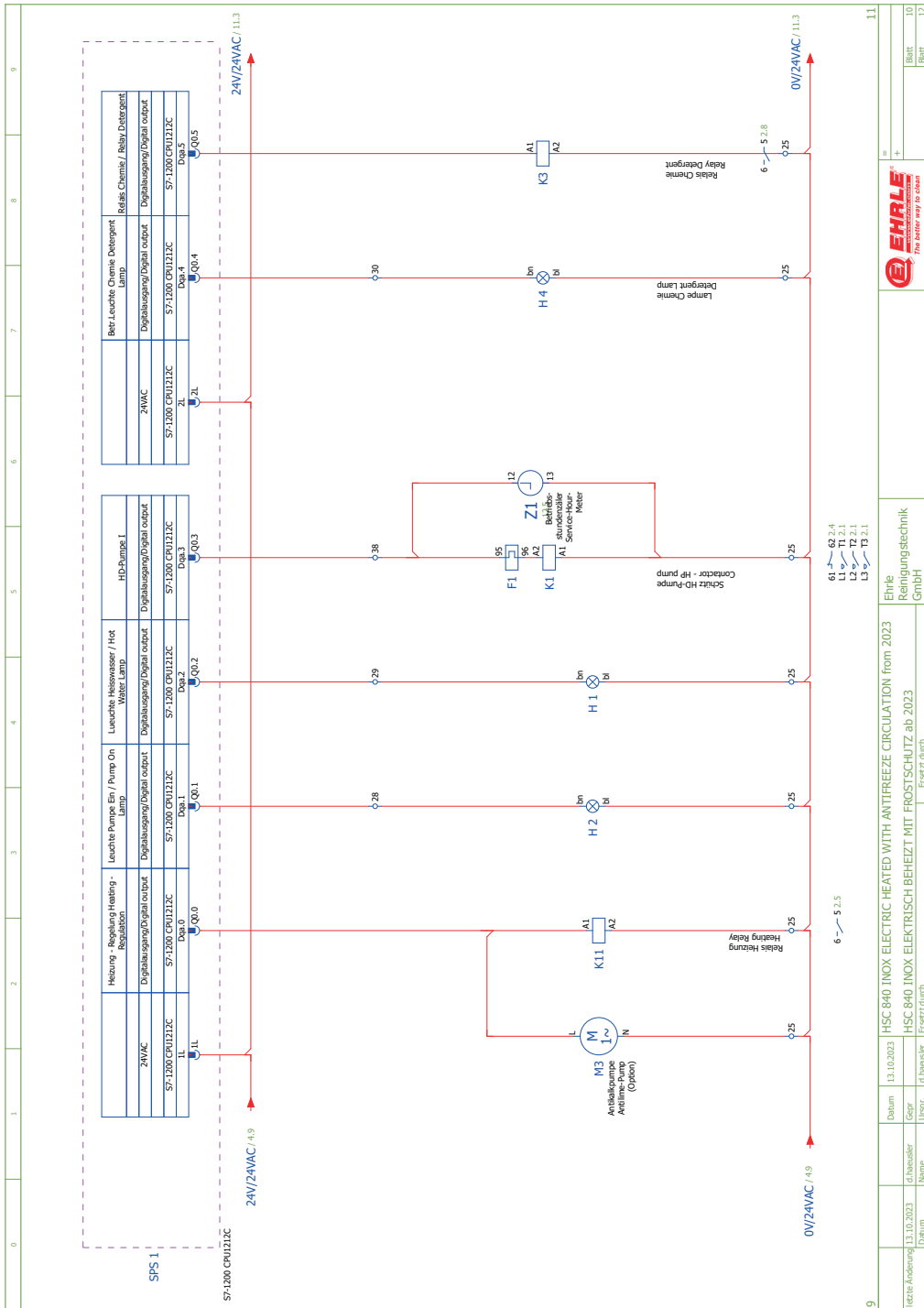

Fig. 10 - 18 HSC840-INOX FR 24 kW, Circuit diagram (Page 10 of 12)

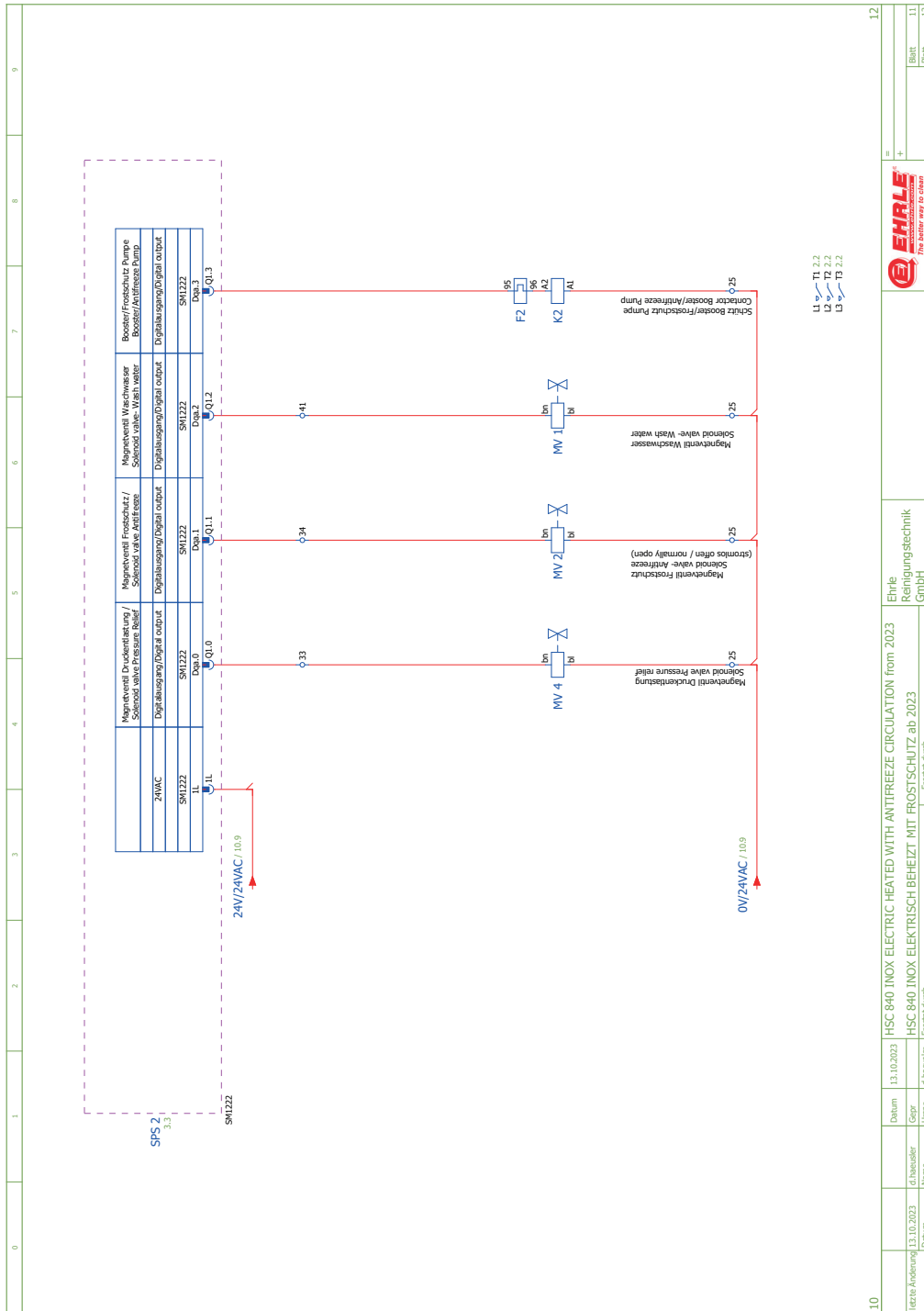

Fig. 10 - 19 HSC840-INOX FR 24 kW, Circuit diagram (Page 11 of 12)



## 10.4 HSC1140-INOX FR 30 kW

0123456789



# EHRLE®

[www.ehrle.com](http://www.ehrle.com)

*The better way to clean*

F26\_001

Projektbeschreibung	HSC 1140 INOX ELEKTRISCH BEHEIZT MIT FROSTSCHUTZ ab 2023
Zeichnungsnummer	HSC 1140 INOX ELECTRIC HEATED WITH ANTIFREEZE CIRCULATION from 2023
Hersteller (Firma)	Ehrle GmbH Industriestraße 3 89165 Dietenheim
Projektname	HSC 1140 INOX ELEKTRISCH BEHEIZT MIT FROSTSCHUTZ ab 2023
Fabrikat	HSC 1140 INOX ELECTRIC HEATED WITH ANTIFREEZE from 2023
Typ	
Erstellt am	19.07.2017
Bereitet am	13.10.2023
Anzahl der Seiten	

---

Datum	19.07.2017	Urspr.	Ljowalek	Ersetzt durch	HSC 1140 INOX ELECTRIC HEATED WITH ANTIFREEZE CIRCULATION from 2023
letzte Änderung	13.10.2023	Gepr.	Ljowalek		HSC 1140 INOX ELEKTRISCH BEHEIZT MIT FROSTSCHUTZ ab 2023
				Ehrle Reinigungstechnik GmbH	
				 The better way to clean	
				Titelblatt / Title Page	
				=	
				+	
				=	
				Seit	
				Seit	
				12	

Fig. 10 - 21 HSC1140-INOX FR 30 kW Circuit diagram (Page 1 of 12)

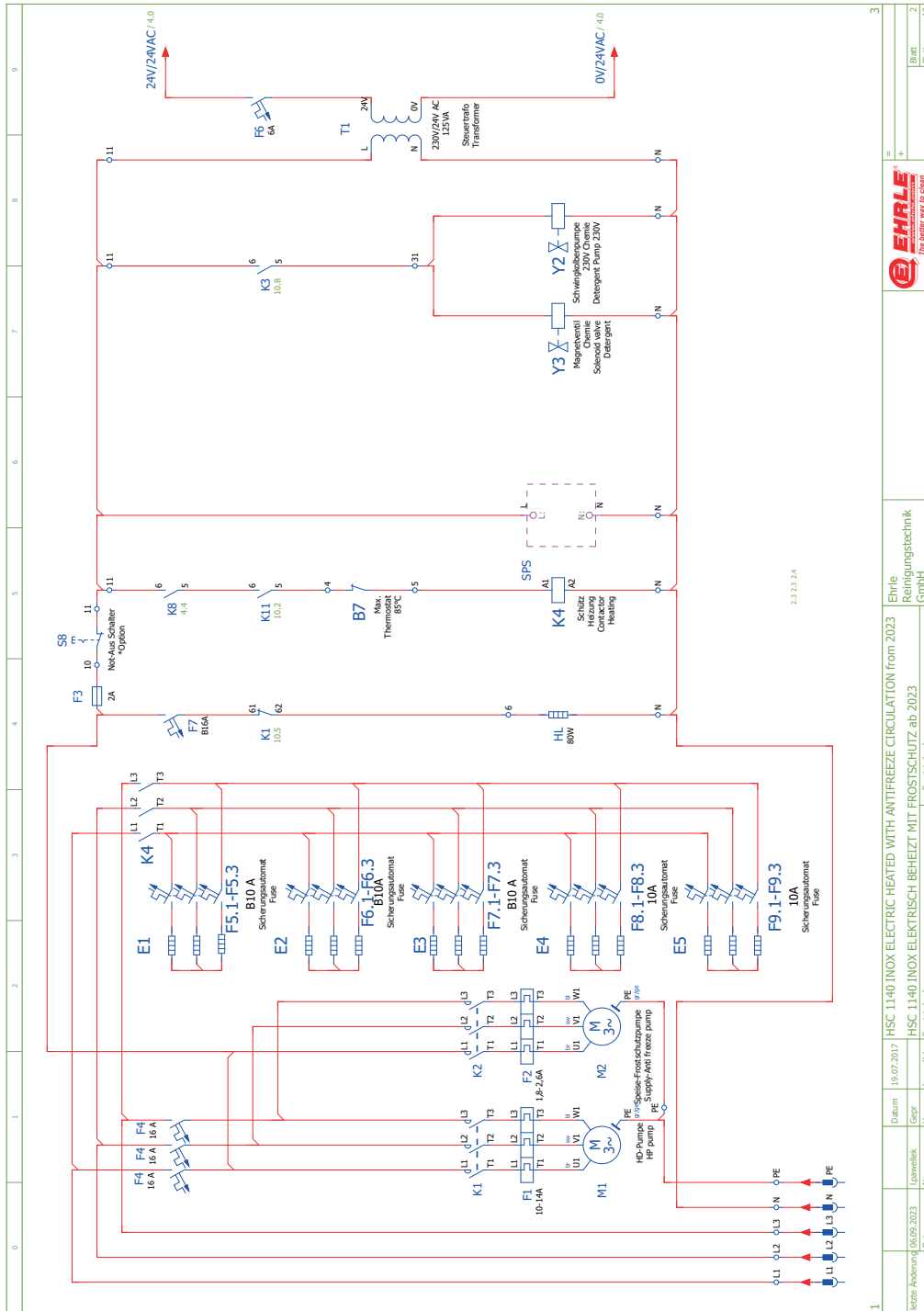

Fig. 10 - 22 HSC1140-INOX FR 30 kW Circuit diagram (Page 2 of 12)

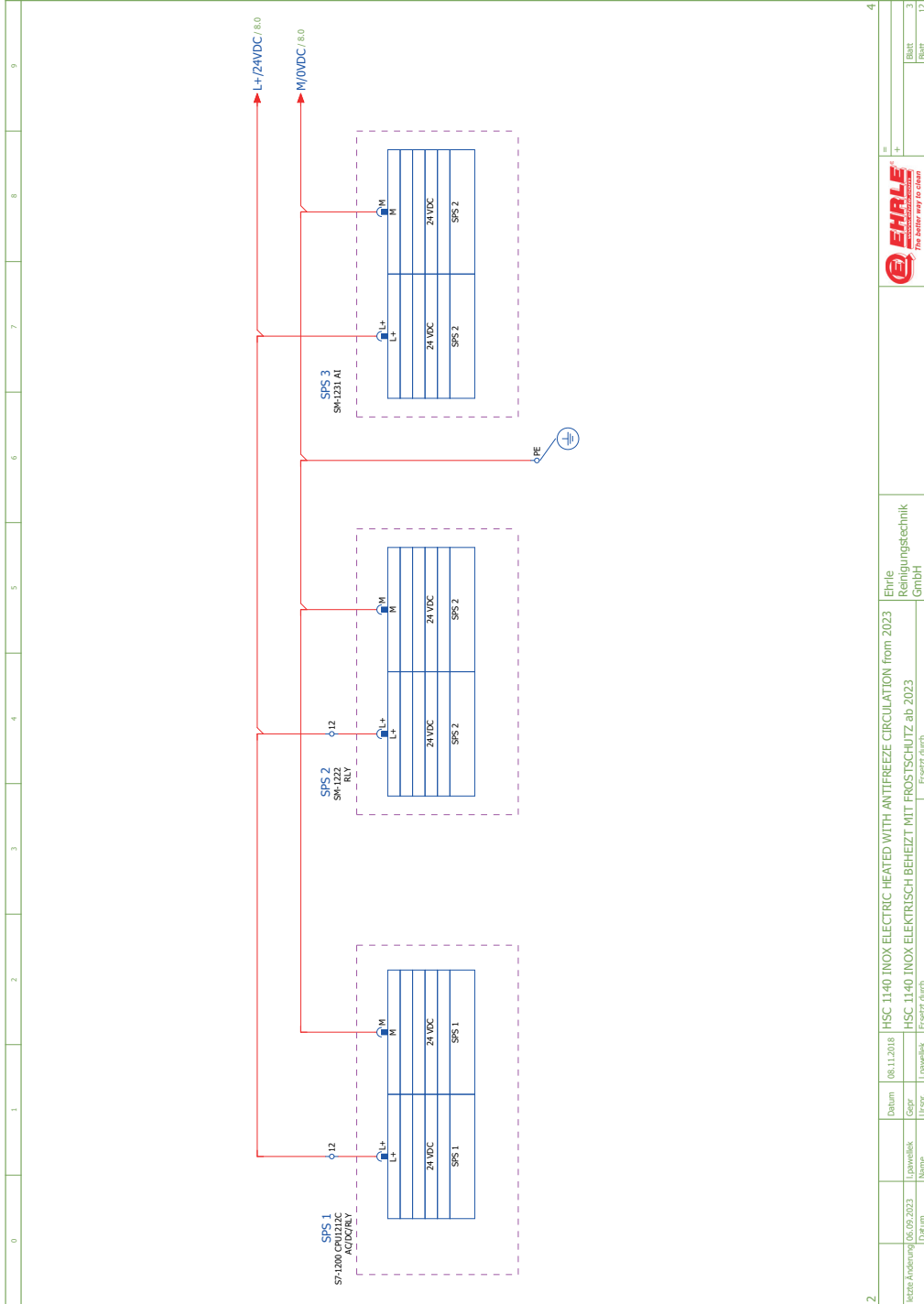

Fig. 10 - 23 HSC1140-INOX FR 30 kW Circuit diagram (Page 3 of 12)

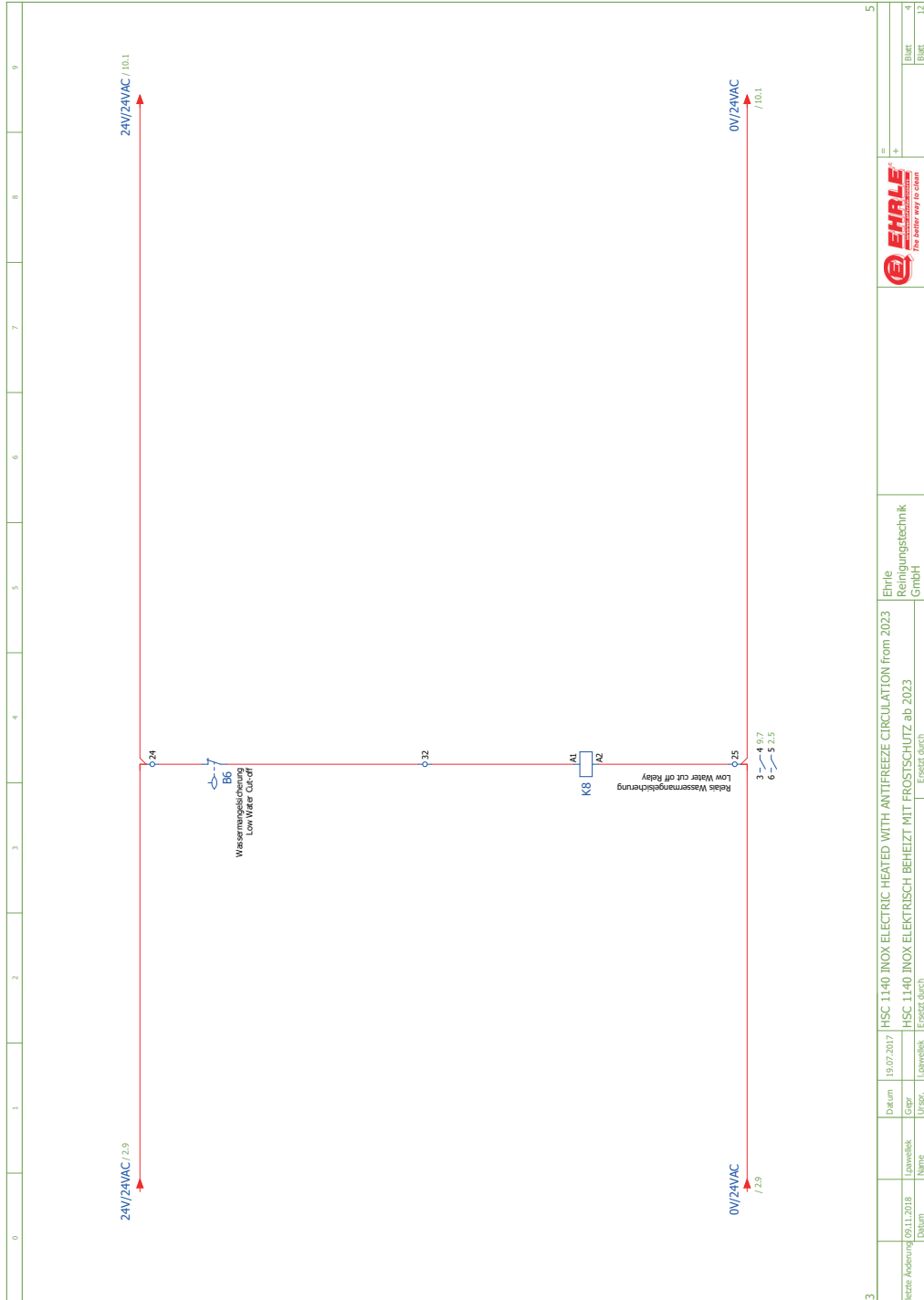
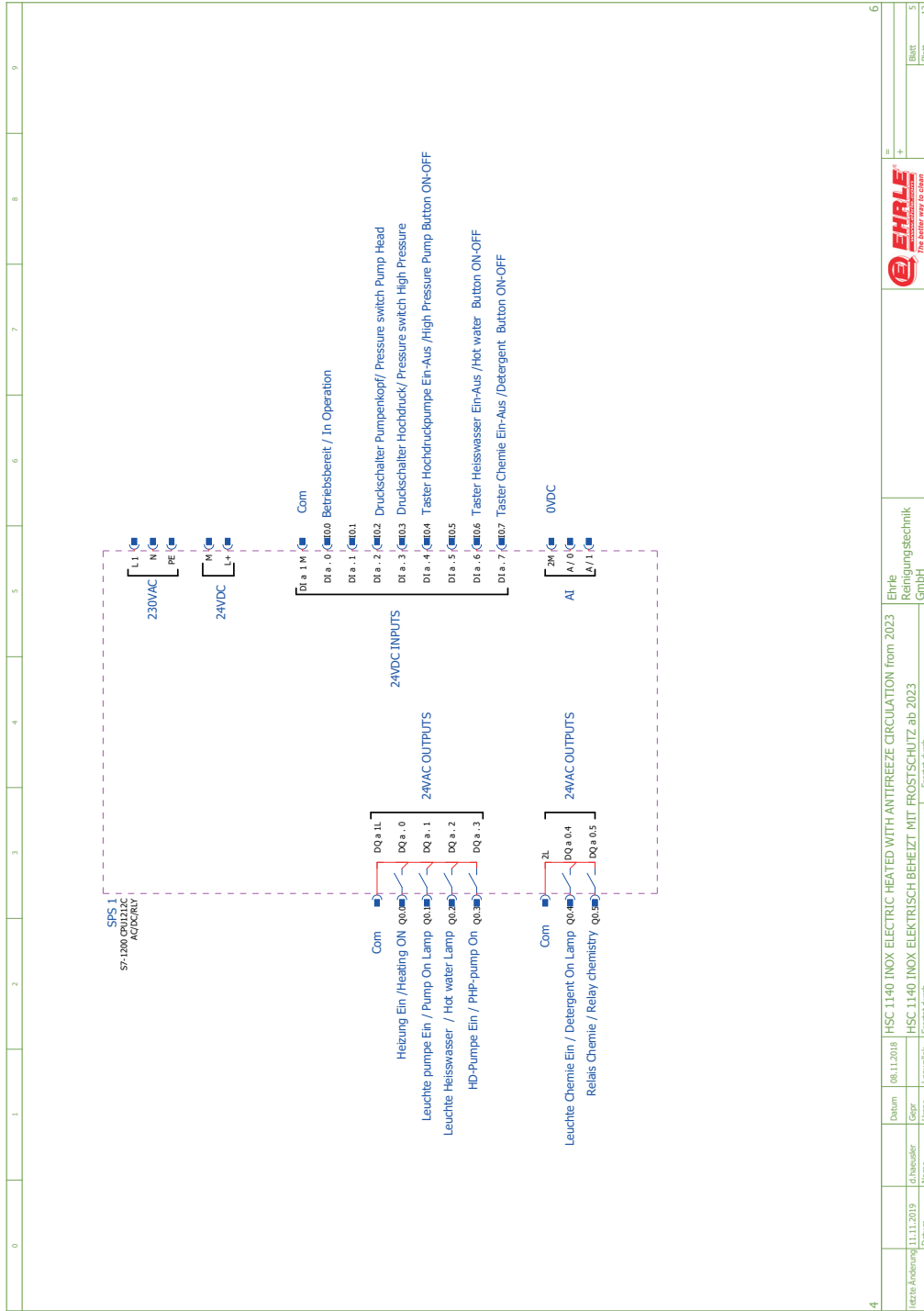

Fig. 10 - 24 HSC1140-INOX FR 30 kW Circuit diagram (Page 4 of 12)



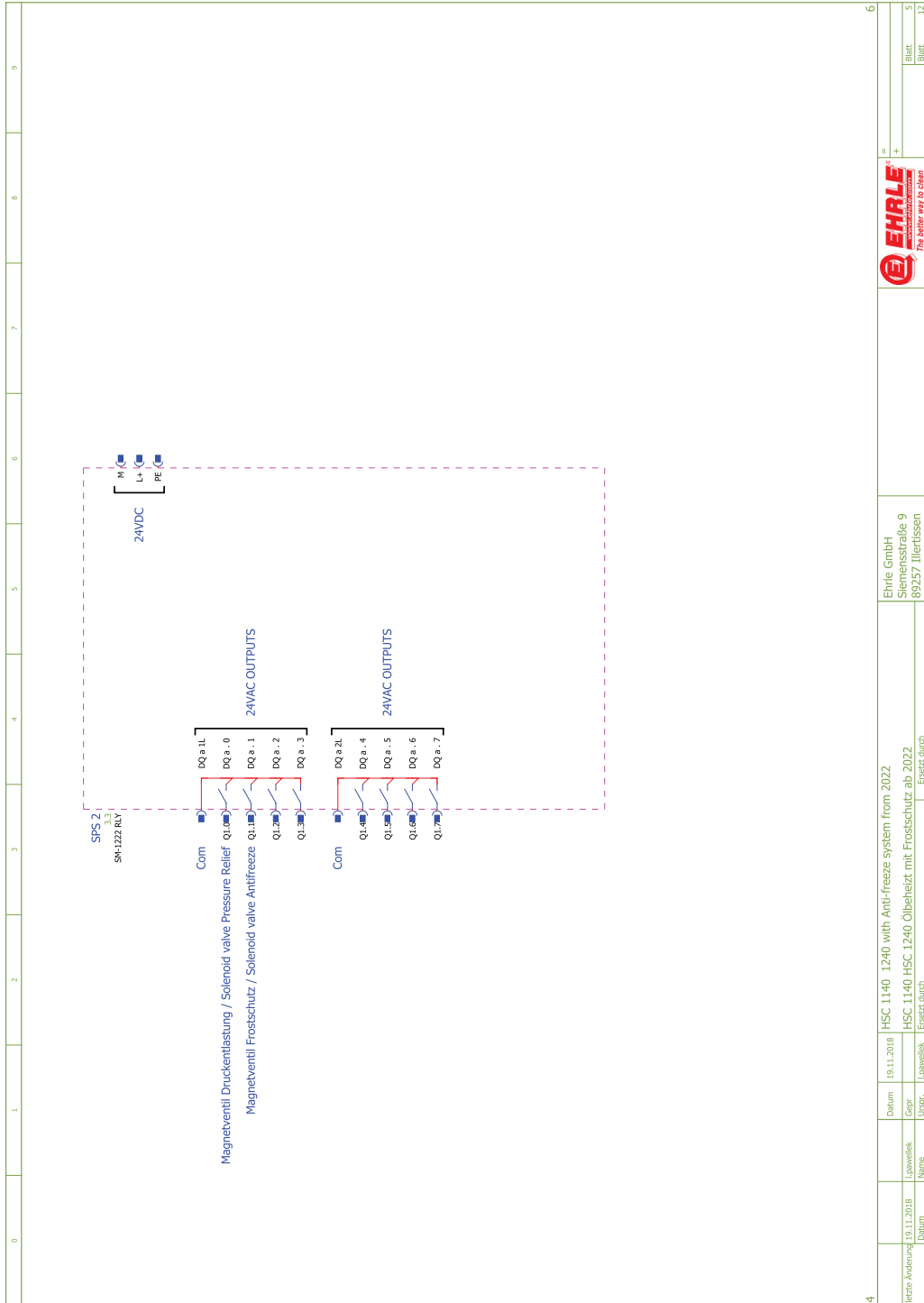

Fig. 10 - 26 HSC1140-INOX FR 30 kW Circuit diagram (Page 6 of 12)



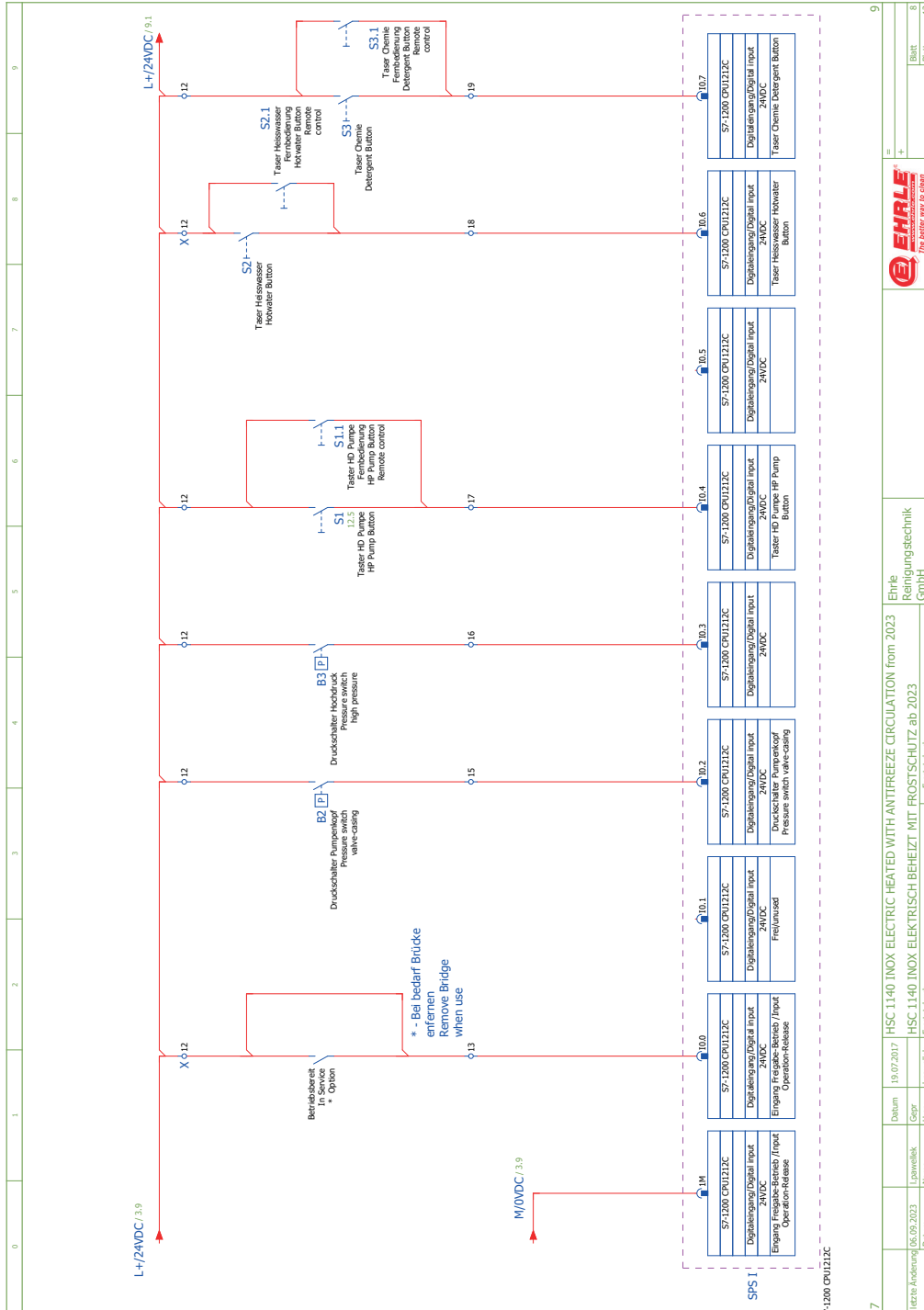

Fig. 10 - 28 HSC1140-INOX FR 30 kW Circuit diagram (Page 8 of 12)

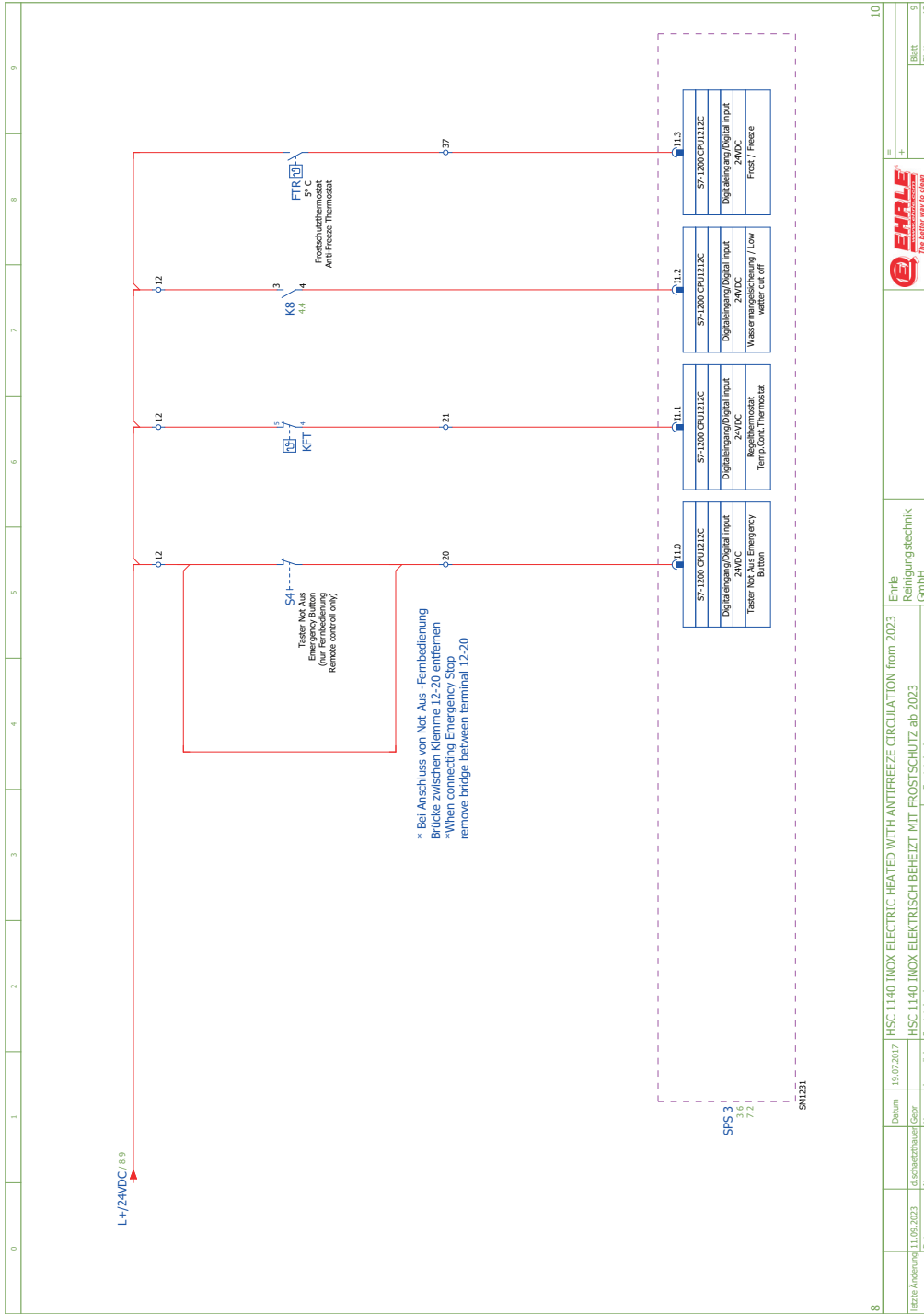

Fig. 10 - 29 HSC1140-INOX FR 30 kW Circuit diagram (Page 9 of 12)

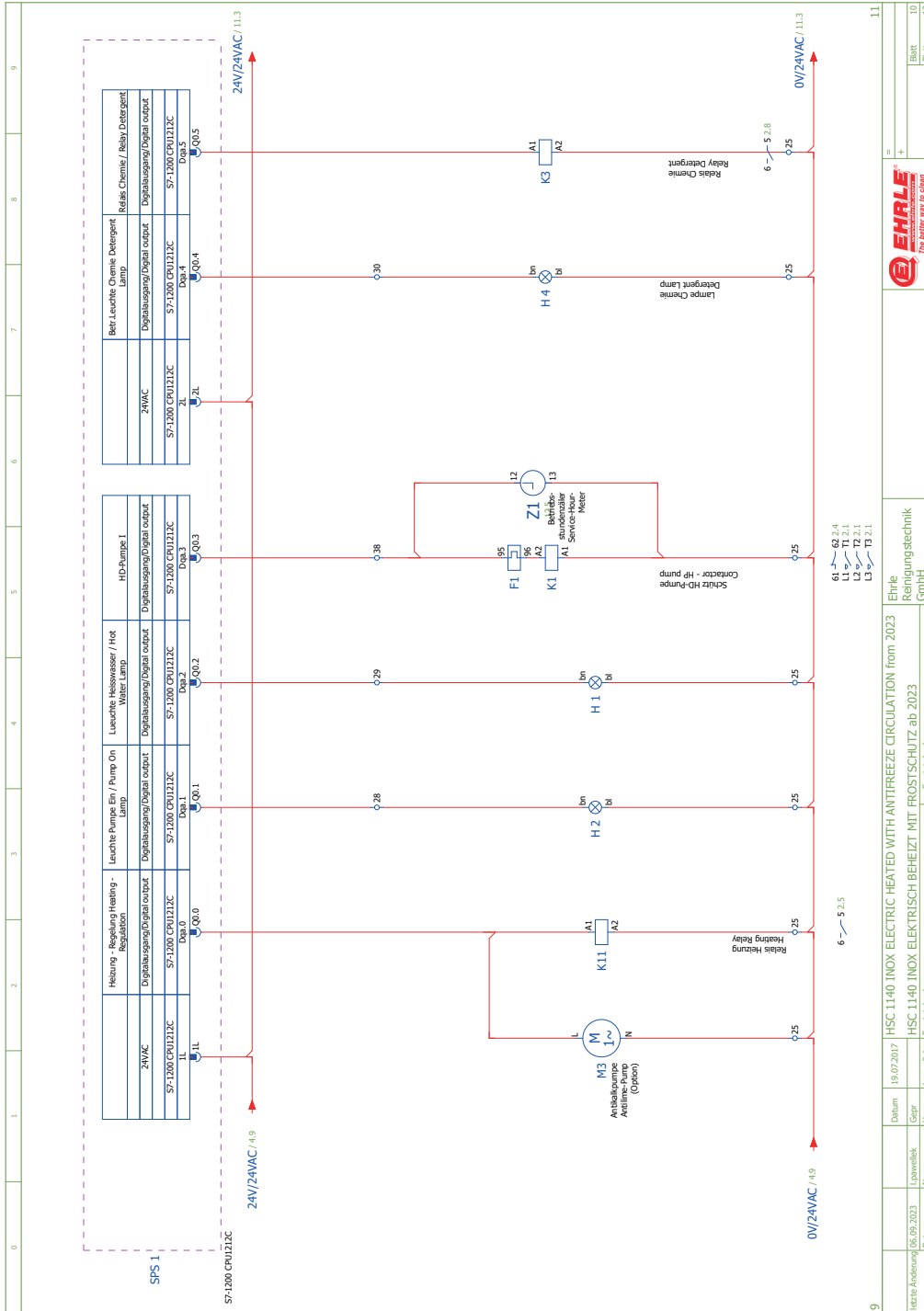

Fig. 10 - 30 HSC1140-INOX FR 30 kW Circuit diagram (Page 10 of 12)

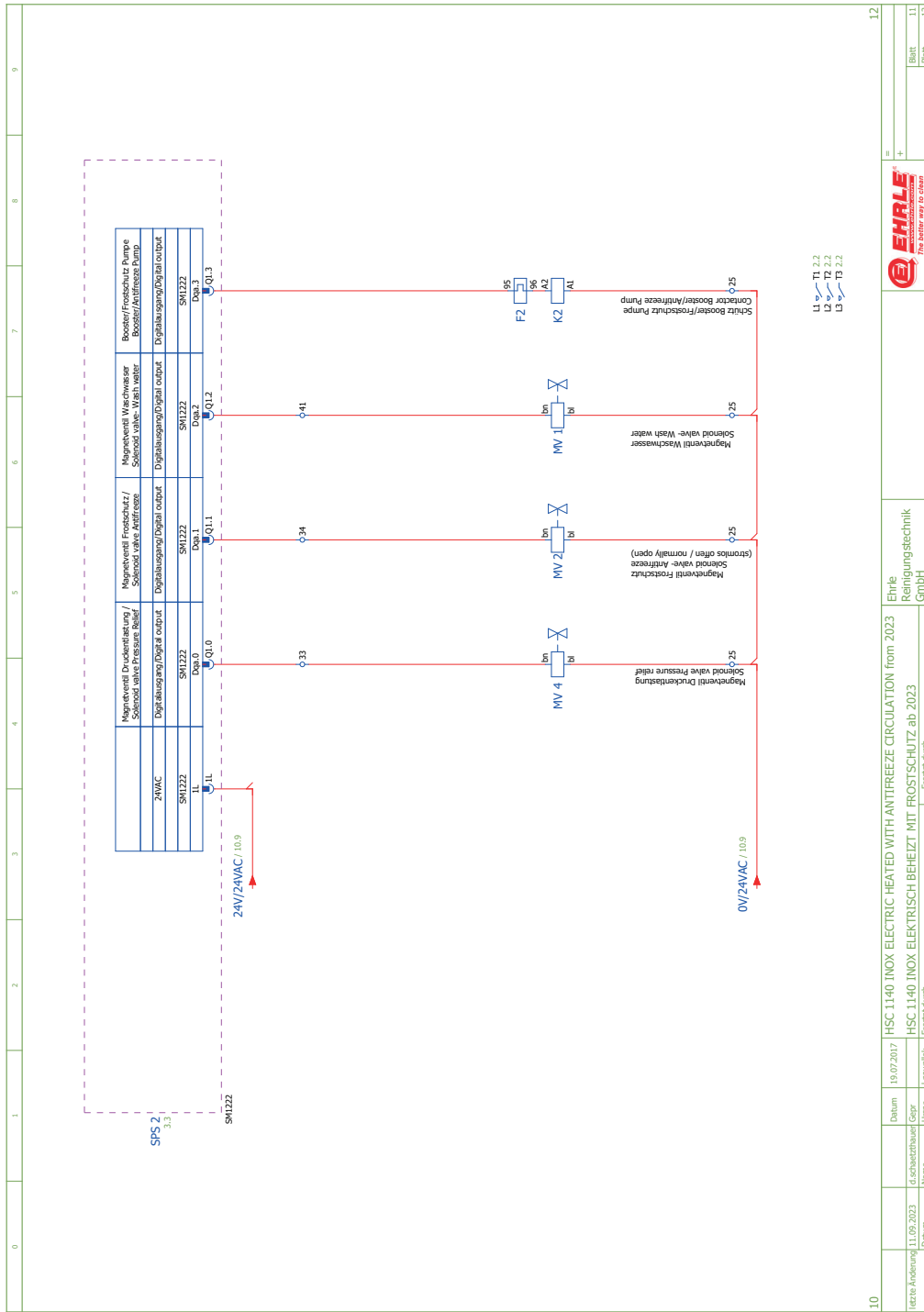
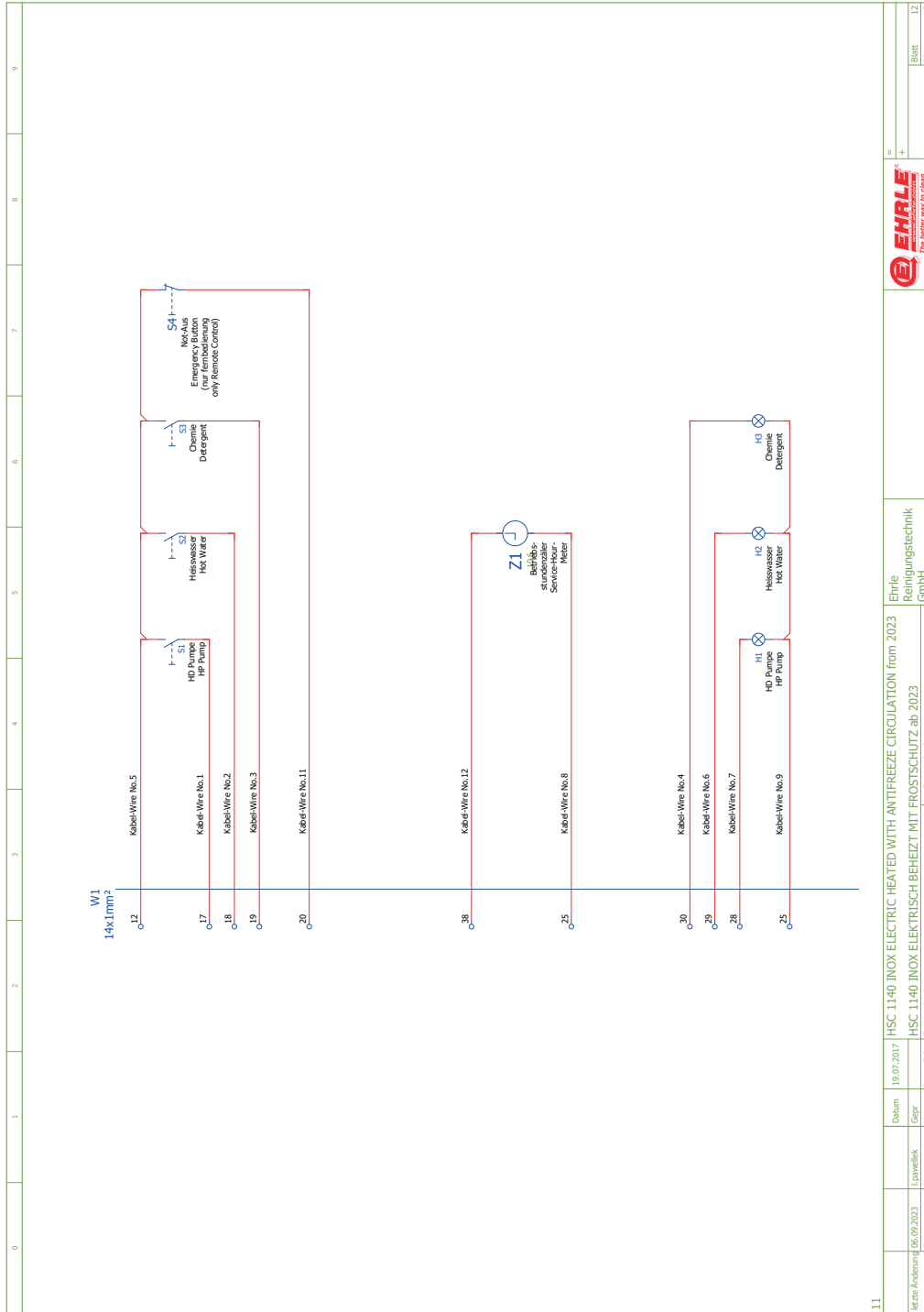

Fig. 10 - 31 HSC1140-INOX FR 30 kW Circuit diagram (Page 11 of 12)



11		HSC 1140 INOX ELECTRIC HEATED WITH ANTIFREEZE CIRCULATION from 2023		Ehrle Reinigungstechnik GmbH	
Datum 19.07.2017		HSC 1140 INOX ELEKTRISCH BEHEIZT MIT FROSTSCHUTZ ab 2023		Erstellt durch	
Gedr. L. Pawelski		Erstellt durch		Blatt	
Unspr. L. Pawelski		Erstellt durch		Blatt	
Name		Erstellt durch		12	
Datum 06.09.2023		Erstellt durch		12	

Fig. 10 - 32 HSC1140-INOX FR 30 kW Circuit diagram (Page 12 of 12)

## 11 General Notes

**Proof of customer service**

System type	Manufacture no.:	Commissioning on:
-------------	------------------	-------------------

Inspection carried out on:

Findings:

Signature:

---

Inspection carried out on:

Findings:

Signature:

---

Inspection carried out on:

Findings:

Signature:

---

Inspection carried out on:

Findings:

Signature:

---

**EHRLE GmbH • 89165 Dietenheim / Germany**

---

EHRLE service near to you? Adresses, phone numbers etc. you will find under [www.ehrle.com](http://www.ehrle.com).

---

Subject to change without notice. Reprint prohibited.

